

YOUNGMAN

INNOVATIVE WORK AT HEIGHT SOLUTIONS

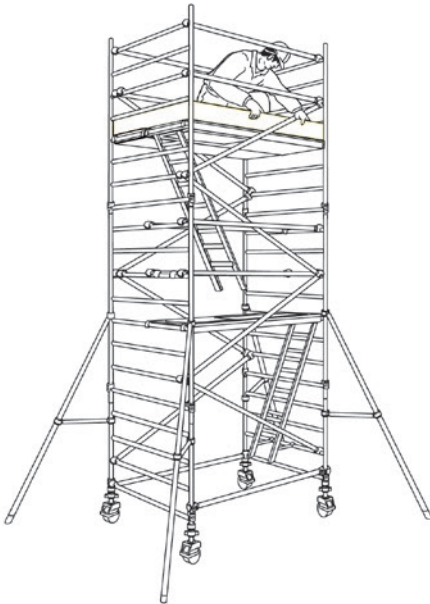

BoSS Clip-in Ladder

Mobile aluminium tower with
inclined clip-in ladder for span frames &
climbing rung frames 1450/850

3T - Through the Trap Method

USER GUIDE
Edition : 1

Safety First

Mobile Towers - 3T Method

INTRODUCTION

Please read this guide carefully.

Please note that diagrams are for illustrative purposes only.

User guides are also available to download from our website at youngmangroup.com

BoSS mobile aluminium towers are light-weight scaffold towers used throughout the building and construction industry for both indoor and outdoor access solutions where a stable and secure platform is required. Ideal for maintenance and installation work or short-term access, the highly versatile towers provide a strong working platform for a variety of heights.

This User Guide provides you with step by step instructions to ensure your system is erected easily and safely using the 3T (Through The Trapdoor) method.

The law requires that personnel erecting, dismantling or altering towers must be competent. Any person erecting a Youngman BoSS mobile tower must have a copy of this guide. For further information on the use of mobile access and working towers consult the PASMA operators code of practice.

If you need further information, design advice, additional guides or any other help with this product, please contact Youngman on +44 (0)1621 745900 or email sales@youngmangroup.com

COMPLIANCES

The BoSS Clima aluminium system has been tested and certified to EN 1004: 2004 Class 3



BS EN 1004:2004

Instruction Manual EN 1298-IM-EN

PREPARATION AND INSPECTION

Inspect the equipment before use to ensure that it is not damaged and that it functions properly. Damaged or incorrect components shall not be used.

Safety First

SAFE USE

- Check that all components are on site, undamaged and that they are functioning correctly – (refer to Checklist and Quantity Schedules). Damaged or incorrect components shall not be used.
- Check if the ground on which the mobile access tower is to be erected and moved is capable of supporting the tower
- The safe working load is 275 kgs (606lbs), per platform level, uniformly distributed up to a maximum of 950kgs (2100lbs), per tower (including self weight).
- Towers must always be climbed from the inside using the clip in ladder during assembly and use.
- It is recommended that towers should be tied to a solid structure when left unattended.
- Adjustable legs should only be used for levelling.

LIFTING OF EQUIPMENT

- Tower components should be lifted using a reliable lifting material (e.g. strong rope), employing a reliable knot (e.g. clove hitch), to ensure safe fastening and always lift within the footprint of the tower
- Assembled mobile towers should not be lifted with a crane or other lifting device.

Safety First

STABILISERS / BALLAST

- Stabilisers or outriggers and ballast weights shall always be fitted when specified.
- The Quantity Schedules show the recommended stabilisation. In circumstances where there is restricted ground clearance for stabilisers/outriggers, contact your supplier for advice. Ballast must be of solid materials (i.e. not water or loose sand) and should not be positioned to overload individual legs. Ballast should be secured against accidental removal where practicable, and be supported on the lowest rung of the bottom frame.

MOVEMENT

- The tower should only be moved by manual effort, and only from the base.
- When moving the tower, beware of live electrical apparatus, particularly overhead, plus wires or moving parts of machinery.
- No person or materials should be on the tower during movement.
- Caution should be exercised when wheeling a tower over rough, uneven or sloping ground, taking care to unlock and lock castors. If stabilisers are fitted, they should only be lifted a maximum of 25mm above the ground to clear ground obstructions.
- The overall height of the tower when being moved, should not exceed 2.5 times the minimum base dimensions, or 4 metres overall height.
- Before use, check the tower is still correct and complete.
- After every movement of the tower use a spirit level to check that it is vertical and level and set the adjustable legs as required.
- Do not move the tower in wind speeds over 7.7 metres per second (17mph).

Safety First

DURING USE

- Beware of high winds in exposed, gusty or medium breeze conditions. We recommend that in wind speeds over 7.7 metres per second (17 mph), cease working on the tower and do not attempt to move it. If the wind becomes a strong breeze, expected to reach 11.3 metres per second (25 mph), tie the tower to a rigid structure. If the wind is likely to reach gale force, over 18 metres per second (40 mph), the tower should be dismantled.

Wind Description	Beaufort Scale	Beaufort No.	Speed in m.p.h	Speed in m/sec
Medium Breeze 4-6	Raises dust and loose paper twigs snap off	4	8 - 12	
Strong Breeze	Large branches in motion, telegraph wires whistle	6	25-31	11-14
Gale Force	Walking is difficult	8	39-46	17-21

- Beware of open ended buildings, which can cause funnelling effect.
- Do not abuse equipment. Damaged or incorrect components shall not be used.
- Raising and lowering components, tools, and/or materials by rope should be conducted within the lower base. Ensure that the safe working load of the supporting decks and the tower structure is not exceeded.
- The assembled tower is a working platform and should not be used as a means of access or egress to other structures.
- Beware of horizontal forces (e.g. power tools) which could generate instability **Maximum horizontal force 20 kg.**
- The stairway towers, featuring an inclined staircase access, are for frequent use by personnel carrying tools and/or materials.
- Mobile towers are not designed to be suspended - please refer to your supplier for advice.
- Do not use boxes or stepladders or other objects on the

Safety First

TIES

- Ties should be used when the tower goes beyond its safe height, beyond the limits of the stabilisers/ outriggers, or if there is a danger of instability They should be rigid, two way ties fastened to both uprights of the frame with load-bearing right angled or swivel couplers. Only couplers suitable for the 50.8mm diameter tube of the tower should be used. Ideally ties should be secured to both faces of a solid structure by means of anchorages.

The tie frequency may vary depending on the application,

- but they should, at a minimum, be every 4 metres height.

For further information on tying-in a tower please contact your supplier or Youngman.

MAINTENANCE - STORAGE - TRANSPORT

All components and their parts should be regularly inspected to identify damage, particularly to joints. Lost

- or broken parts should be replaced, and any tubing with indentation greater than 5mm should not be used and put to one side for manufacture repair Adjustable leg threads should be cleaned and lightly lubricated to keep them free running.

Brace claws, frame interlock clips, trapdoor latches and platform windlocks should be regularly checked to ensure

- they lock correctly

Refer to the BoSS Inspection Manual for detailed inspection and maintenance advice

- Components should be stored with due care to prevent damage.
- Ensure components are not damaged by excessive strapping forces when transported.
-

Safety First

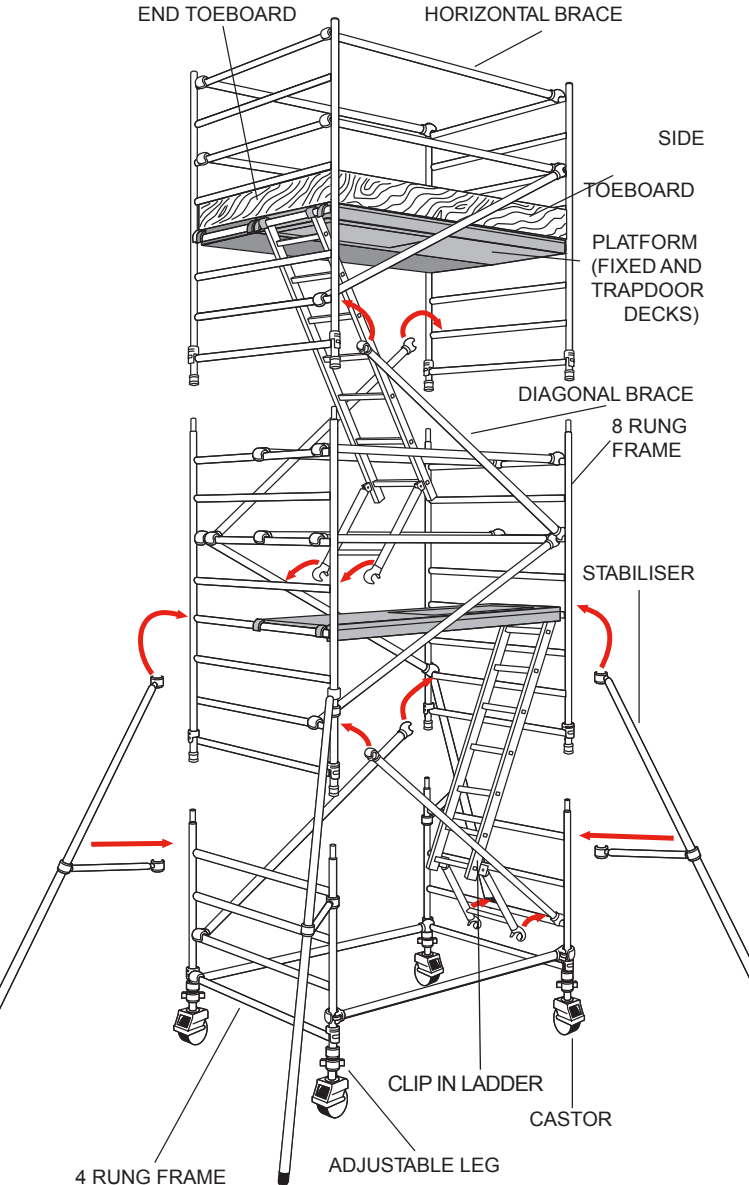

Quantity Schedule

1450 Width Towers

BoSS Clip-in Ladder using LADDERSPAN to EN1004:
Available in 2 lengths - 1.8m and 2.5m.

Internal/External Use - Towers under 2.5 are outside scope of EN1004

BoSS Ladder Span 1450mm Wide x 1.8 & 2.5m

3T build

Internal
& External

External
Only

	4.2	6.2	8.2	10.2	12.2	14.2
Working Height (m)	4.2	6.2	8.2	10.2	12.2	14.2
Platform Height (m)	2.2	4.2	6.2	8.2	10.2	12.2
Component						
Ø125mm, Ø150mm, Ø200mm Castor	4	4	4	4	4	4
Adjustable Leg	4	4	4	4	4	4
2 rung Span Frame (1.0m high x 0.85m wide)	2	2	2	2	2	2
4 rung Span Frame (2.0m high x 0.85m)		4	6	8	10	12
1.8m Trap Door Deck	1	2	3	4	5	6
1.8m Fixed Deck	1	1	1	1	1	1
1.8m Horizontal Brace	6	10	14	18	22	26
2.1m Diagonal Brace	3	7	11	15	19	23
1.8m Side Toe Board	2	2	2	2	2	2
0.6m End Toe Board	2	2	2	2	2	2
Toe Board Holder	4	4	4	4	4	4
7 rung Clip-in Ladder	1	2	3	4	5	6
SP7	4	4				
SP10			4		4	4
SP15				4		
Weight - 1.8m	129	180	243	309	345	397
Weight - 2.5m	145	205	277	352	396	456

Quantity Schedule

1450 Width Towers

BoSS CLIP-IN LADDER USING CLIMA TO EN1004:

AVAILABLE IN 2 LENGTHS - 1.8M AND 2.5M.

INTERNAL/EXTERNAL USE - TOWERS UNDER 2.5 ARE OUTSIDE SCOPE OF EN1004

BoSS Clima 1450mm Wide x 1.8 & 2.5m

3T BUILD

INTERNAL & EXTERNAL

EXTERNAL

Only

	4.2	6.2	8.2	10.2	12.2	14.2
WORKING HEIGHT (M)	4.2	6.2	8.2	10.2	12.2	14.2
PLATFORM HEIGHT (M)	2.2	4.2	6.2	8.2	10.2	12.2
Component						
Ø125MM, Ø150MM,	4	4	4	4	4	4
ADJUSTABLE LEG	4	4	4	4	4	4
4 RUNG SPAN FRAME (1.0M HIGH X 0.85M WIDE)	2	2	2	2	2	2
8 RUNG SPAN FRAME (2.0M HIGH X 0.85M)		4	6	8	10	12
1.8M TRAP DOOR DECK	1	2	3	4	5	6
1.8M FIXED DECK	1	1	1	1	1	1
1.8M HORIZONTAL BRACE	6	10	14	18	22	26
2.1M DIAGONAL BRACE	3	7	11	15	19	23
1.8M SIDE TOE BOARD	2	2	2	2	2	2
0.6M END TOE BOARD	2	2	2	2	2	2
TOE BOARD HOLDER	4	4	4	4	4	4
7 RUNG CLIP-IN LADDER	1	2	3	4	5	6
SP7	4	4				
SP10			4		4	4
SP15				4		
WEIGHT - 1.8M	121	177	246	316	358	414
WEIGHT - 2.5M	133	197	274	353	403	468

Quantity Schedule

1450 WIDTH TOWERS

NUMBER OF WORKING PLATFORMS ALLOWED

The MAXIMUM SAFE WORKING LOAD (the combined weight of the users, tools and materials) that may be placed on the tower is the total weight less the self weight of the tower. The total weight for the towers shown in the schedule is 950kg.

Example 1:

A 1450 Clima tower built using the 3T method with a 4.2m platform height and a platform length of 1.8m has a self weight of 177kg.

$950\text{kg} - 177\text{kg} = 773\text{kg}$ maximum safe working load
total weight self weight (users, tools and materials)

Example 2:

A 1450 Clima tower built using the 3T method with a 10.2m platform height and a platform length of 2.5m has a self weight of 403kg.

$950\text{kg} - 403\text{kg} = 547\text{kg}$ maximum safe working load
total weight self weight (users, tools and materials)

For greater heights and loads, consult Youngman for guidance.

PLATFORM LOADING

On a 1450 tower a platform may comprise of a single deck or two decks placed side by side. The maximum safe working load (the combined weight of the users, tools and materials) that may be placed on a platform is 275kg. This must be evenly distributed over either one deck, or two decks placed side by side.

The quantities on pages 7 and 8, will enable BoSS towers to be built safely and therefore comply with the requirements of the Work at Height Regulations. They include double guardrails to all platforms, and toeboards will need to be added if any levels are used as working platforms and for storage of materials.

EN 1004 requires platforms at least every 4.2m, and these measures will exceed that requirement.

Quantity Schedule

1450 WIDTH TOWERS

BALLAST: Internal/External Use

There is no requirement for ballast on 1450 towers if using stabilisers as detailed in the table on **page 8 & 9**.

MOBILE OUTRIGGERS

MP16 outriggers can be used instead of SP15 stabilisers, as detailed below. Mobile outrigger kits comprise:

Mobile Outrigger Kit

MP16 Mobile Outrigger	4
125/150/200mm Castor (Use same diameter castors as on tower)	4
250mm Adjustable leg	4
Plan Braces	4
The above components replace:	
SP15 Stabiliser	4

STABILISERS

To improve rigidity, larger stabilisers can be used at a lower level than shown in the table on **page 8**.

Angle of Stabiliser 1450 TOWER

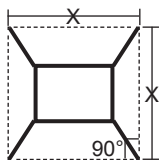

Double width 1450 Towers Dimension X

	Platform Length 1.8m	Platform Length 2.5m
SP7	X= 3351	X= 3629
SP10	X= 4789	X= 5100
SP15	X= 5520	X= 5838

Quantity Schedule

850 Width Towers

BoSS CLIP-IN LADDER USING LADDERSPAN TO EN1004:
AVAILABLE IN 2 LENGTHS - 1.8M AND 2.5M.

BoSS Ladder Span 850mm Wide x 1.8 & 2.5m

3T BUILD

Internal
& EXTERNAL

EXTERNAL
Only

	4.2	6.2	8.2	10.2	12.2	14.2	
WORKING HEIGHT (M)	4.2	6.2	8.2	10.2	12.2	14.2	
PLATFORM HEIGHT (M)	2.2	4.2	6.2	8.2	10.2	12.2	
Component							
Ø125MM, Ø150MM, Ø200MM CASTOR	4	4	4	4	4	4	
ADJUSTABLE LEG	4	4	4	4	4	4	
2 RUNG SPAN FRAME (1.0M HIGH X 0.85M WIDE)	2	2	2	2	2	2	
4 RUNG SPAN FRAME (2.0M HIGH X 0.85M WIDE)		4	6	8	10	12	
1.8M TRAP DOOR DECK	1	2	3	4	5	6	
1.8M FIXED DECK	0	0	0	0	0	0	
1.8M HORIZONTAL BRACE	6	10	14	18	22	26	
2.1M DIAGONAL BRACE	3	7	11	15	19	23	
1.8M SIDE TOE BOARD	2	2	2	2	2	2	
0.6M END TOE BOARD	2	2	2	2	2	2	
TOE BOARD HOLDER	4	4	4	4	4	4	
7 RUNG CLIP-IN LADDER	1	2	3	4	5	6	
SP7	4	4					
SP10			4		4	4	
SP15				4			
WEIGHT - 1.8M	108	156	217	280	313	361	
WEIGHT - 2.5M	120	176	245	317	359	416	

Quantity Schedule

850 Width Towers

BoSS CLIP-IN LADDER USING CLIMA TO EN1004:

AVAILABLE IN 2 LENGTHS - 1.8M AND 2.5M.

BoSS Clima 850mm Wide x 1.8 & 2.5m

3T BUILD

Internal
& EXTERNAL

EXTERNAL
Only

	4.2	6.2	8.2	10.2	12.2	14.2
WORKING HEIGHT (M)	4.2	6.2	8.2	10.2	12.2	14.2
PLATFORM HEIGHT (M)	2.2	4.2	6.2	8.2	10.2	12.2
Component						
Ø125MM, Ø150MM, Ø200MM CASTOR	4	4	4	4	4	4
ADJUSTABLE LEG	4	4	4	4	4	4
4 RUNG SPAN FRAME (1.0M HIGH X 0.85M WIDE)	2	2	2	2	2	2
8 RUNG SPAN FRAME (2.0M HIGH X 0.85M WIDE)		4	6	8	10	12
1.8M TRAP DOOR DECK	1	2	3	4	5	6
1.8M FIXED DECK	0	0	0	0	0	0
1.8M HORIZONTAL BRACE	6	10	14	18	22	26
2.1M DIAGONAL BRACE	3	7	11	15	19	23
1.8M SIDE TOE BOARD	2	2	2	2	2	2
0.6M END TOE BOARD	2	2	2	2	2	2
TOE BOARD HOLDER	4	4	4	4	4	4
7 RUNG CLIP-IN LADDER	1	2	3	4	5	6
SP7	4	4				
SP10			4		4	4
SP15				4		
WEIGHT - 1.8M	111	161	224	289	325	375
WEIGHT - 2.5M	122	181	253	326	370	429

Quantity Schedule

850 Width towers

NUMBER OF WORKING PLATFORMS ALLOWED

The MAXIMUM SAFE WORKING LOAD (the combined weight of the users, tools and materials) that may be placed on the tower is the total weight less the self weight of the tower. The total weight for the towers shown in the schedule is 950kg.

Example 1:

An 850 Ladderspan tower built using the 3T method with a 4.2m platform height and a platform length of 1.8m has a self weight of 156kg.

$950\text{kg} - 156\text{kg} = 794\text{kg}$ maximum safe working load
total weight self weight (users, tools and materials)

Example 2:

An 850 Ladderspan tower built using the 3T method with a 10.2m platform height and a platform length of 2.5m has a self weight of 359kg.

$950\text{kg} - 359\text{kg} = 591\text{kg}$ maximum safe working load
total weight self weight (users, tools and materials)
For greater heights and loads, consult Youngman for guidance.

PLATFORM LOADING

On an 850 tower a platform comprises of a single deck only. The maximum safe working load (the combined weight of the users, tools and materials) that may be placed on a platform is 275kg, evenly distributed over the deck.

The quantities on **pages 11 and 12**, will enable BoSS towers to be built safely and therefore comply with the requirements of the Work at Height Regulations. They include double guardrails to all platforms, and toeboards will need to be added if any levels are used as working platforms and for storage of materials. EN 1004 requires platforms at least every 4.2m, and these measures will exceed that requirement.

Quantity Schedule

850 Width Towers

BALLAST: Internal/External Use

There is no requirement for ballase on 850 towers if using stabilisers as detailed in the table on page 12

MOBILE OUTRIGGERS

MP16 mobile outriggers can be used instead of SP15 telescopic stabilisers respectively, as detailed below. Mobile outrigger kits comprise:

Mobile Outrigger Kit

MP16 Mobile Outrigger	4
125/150/200mm Castor (Use same diameter castors as on tower)	4
250mm Adjustable leg	4
Plan Braces	4
The above components replace:	
SP15 Stabiliser	4

STABILISERS

To improve rigidity, larger stabilisers can be used at a lower level than shown in the table on **page 12**.

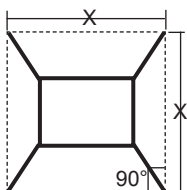

Single Width 850 Towers Dimension X

	Platform Length 1.8m	Platform Length 2.5m
SP7	X= 2994	X= 3201
SP10	X= 4458	X= 4734
SP15	X= 5195	X= 5485

ASSEMBLY PROCEDURE

Mobile Towers - 3T Method

ASSEMBLY AND DISMANTLING PROCEDURES

When building a BoSS Tower:

- To comply with the Work at Height Regulations we show assembly procedures with platforms every 2 metres in height, and, the locating of guardrails in advance of climbing onto a platform to reduce the risk of a fall.
- All platforms feature double guardrails on both faces of either individual platforms or fully decked levels.
- All guardrails should be 2 and 4 rungs (0.5m and 1.0m) above platforms.
- Never stand on an unguarded platform positioned above the first rung of a tower. If your risk assessment shows it necessary, you may also need to guardrail platforms at this level.
- **Always start building with the smallest height frames at the base of the tower:**

PLATFORM HEIGHTS IN METRES	Frame at base
2.2, 4.2, 6.2, 8.2, 10.2, 12.2	4 rung

TO DISMANTLE A BOSS CLIP-IN LADDER TOWER

- Remove toeboards, and pass down the tower
- Unclip farthest end of braces and immediately go to protected trapdoor position on ladder to complete removal.
- Remove upper platforms from protected platform levels below
- Pass removed components out of the tower to a colleague.

Safety Checklist

Mobile Towers - 3T Method

CHECKLIST

Ensure all brace claws operate and lock correctly prior to erection	✓
Inspect components prior to erection	✓
Inspect tower prior to use	✓
Tower upright and level	✓
Castors locked and legs correctly adjusted	✓
Diagonal braces fitted	✓
Stabilisers/outriggers fitted as specified	✓
Platforms located and windlocks on	✓
Toeboards located	✓
Check guardrails are fitted correctly See illustration below	✓

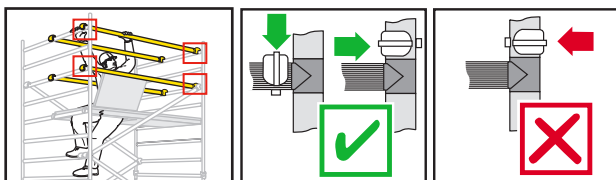

Ensure horizontal braces and guardrails are fitted correctly
Always fit as shown.

Refer to this checklist before using each time.

ASSEMBLY PROCEDURE

Mobile Towers - 1450 3T Method

ASSEMBLY FOR 1450 TOWERS

Always start building with the smallest height frames at the base of the tower:

PLATFORM HEIGHTS IN METRES	Frame at base
2.2, 4.2, 6.2, 8.2, 10.2, 12.2	4 rung

The procedure illustrated shows a CLIMA tower starting with a 4 rung frame.

Youngman recommend two persons are used to build BoSS Towers. **Above 4m height, it is essential that at least two persons are used.** Only climb the tower from the inside.

- 1** Push 4 castors onto 4 adjustable legs. Insert adjustable legs into 2 end frames as shown. Lock castor brakes. Base plates can be fitted to adjustable legs if it is not necessary to move the tower

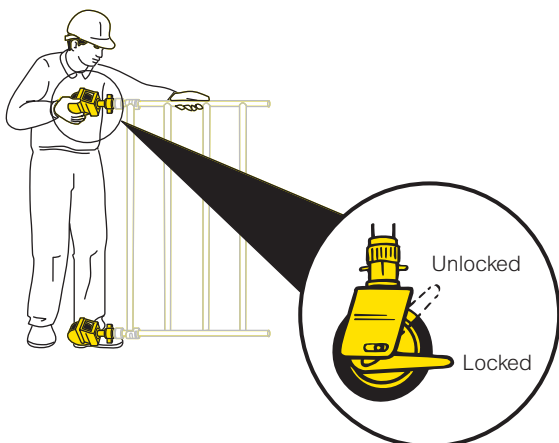

ASSEMBLY PROCEDURE

- 2** Fit one horizontal brace (red) onto the vertical of an end frame, just above the bottom rung, with the claw facing outwards.

Note: All locking claws must be opened before fitting.

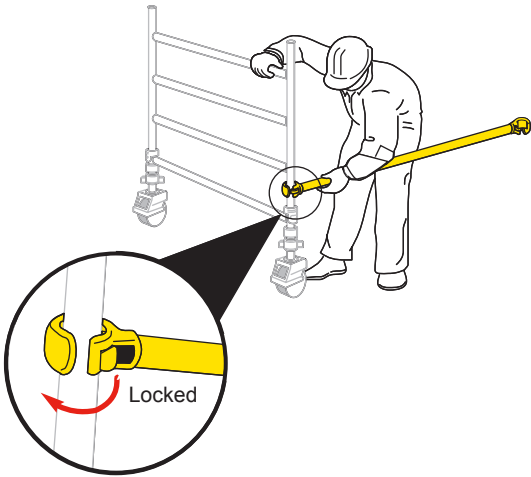

- 3** Position the second end frame as shown and fit the other end of the horizontal brace on to the vertical, just above the bottom rung. Fit a second horizontal brace between the bottom rungs on the other side of the frames to square the tower

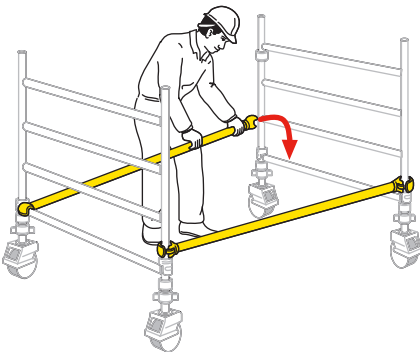

ASSEMBLY PROCEDURE

4 Fit 2 additional end frames and check the frame interlock clips are engaged. Fit 2 diagonal braces (blue) in opposing directions, between the 2nd and the 6th rungs. Ensure the frames are vertical and level by checking with a spirit level and setting the adjustable legs as required.

IMPORTANT – Only use the adjustable legs to level the tower and not to gain extra height.

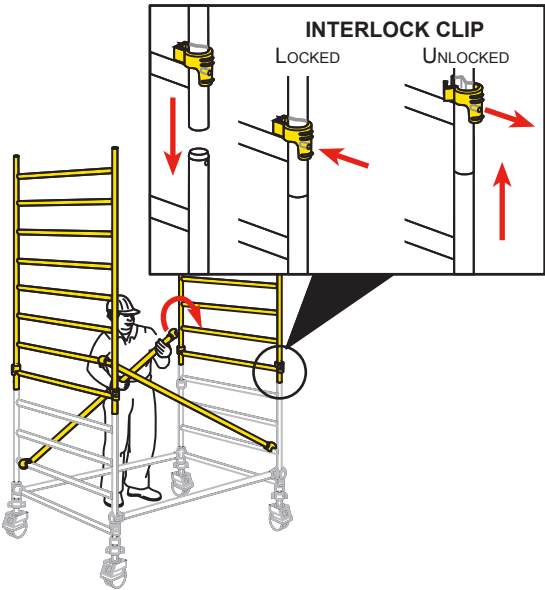

Fit the stabilisers. (See the notes on page 27)



ASSEMBLY PROCEDURE

Fit Clip-in Ladder by firstly hooking the top over the 8th rung.

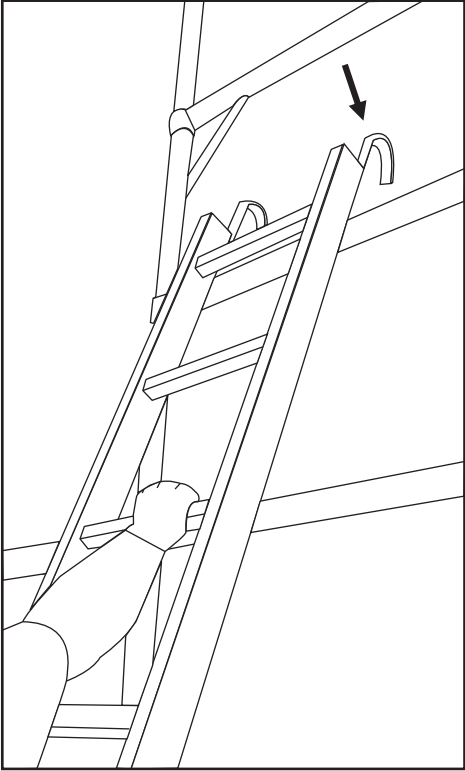

Then lock the the 2 claws onto the 2nd rung.

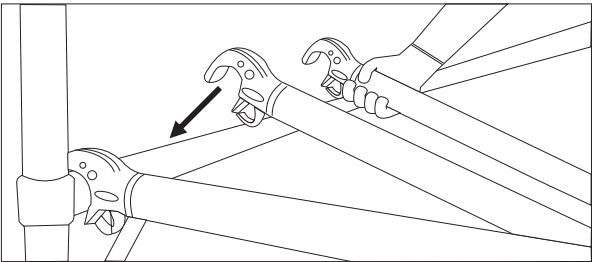

ASSEMBLY PROCEDURE

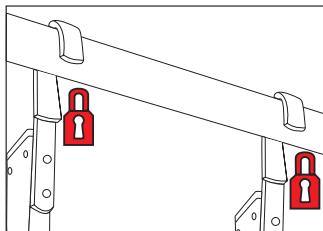
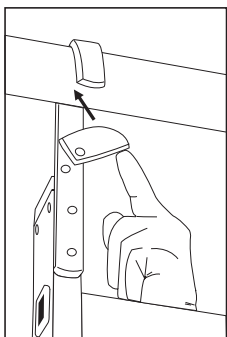

Finally lock the ladder in place by pushing both locking tabs in to the upright position

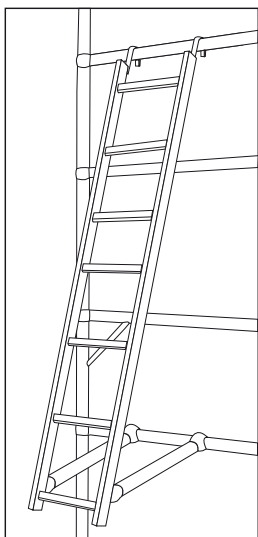

ENSURE THAT CLIP IN LADDER HOOKS ARE POSITIONED INSIDE THE DECK HOOKS, AS SHOWN.

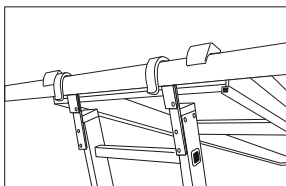

ASSEMBLY PROCEDURE

5 Fit a temporary deck on the lowest rungs. Fit a trapdoor deck on the 8th rung (2.0m) with the trapdoor above the Clip in ladder. Climb the end frame below the trapdoor on the inside of the tower and from within the protected trapdoor position, fit horizontal braces on the 10th and 12th rungs (in that order) on both sides of the deck.

Do not climb onto the deck until it is fully guardrailed.

When horizontal braces are fitted as guardrails, they should be 0.5m and 1.0m (2 and 4 rungs) above the deck level.

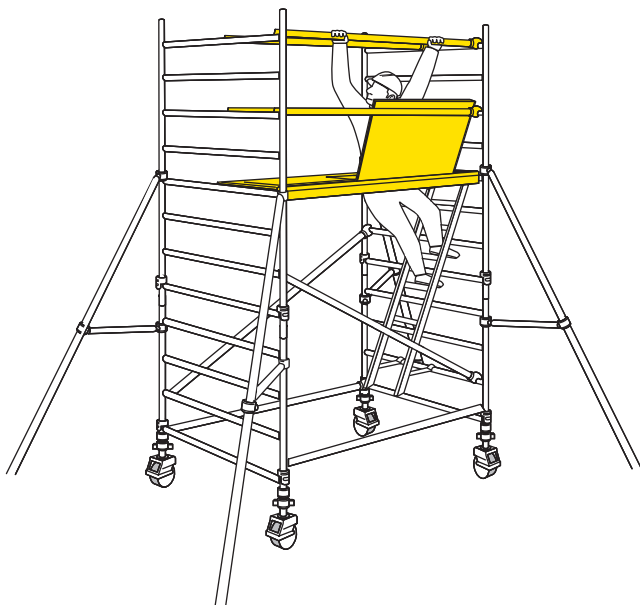

ASSEMBLY PROCEDURE

- 6** Fit the next pair of diagonal braces in opposing directions between the 6th and 10th rungs add 2 additional end frames.

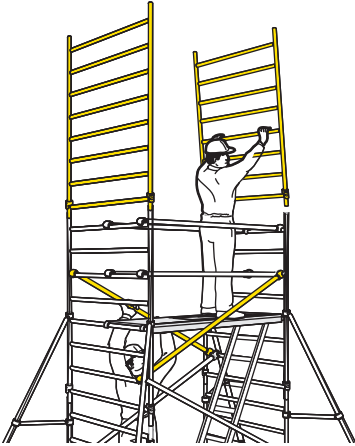

Add two more diagonal braces between the 10th and 14th rungs. Place a Clip in ladder at the opposite end of the tower, as shown, on the 16th rung. If finishing at this height (4.2m platform), the fixed deck should be positioned on the 16th rung on the opposite side of the tower to the trapdoor deck. Fit a trapdoor deck alongside it with the trapdoor above the Clip in ladder. Climb the ladder and from the protected trapdoor position, fit the horizontal braces as guardrails on both sides at 2 and 4 rungs (0.5 and 1.0m) above the platform level. At the final level, a further diagonal braces should be added on one side of the tower as shown.

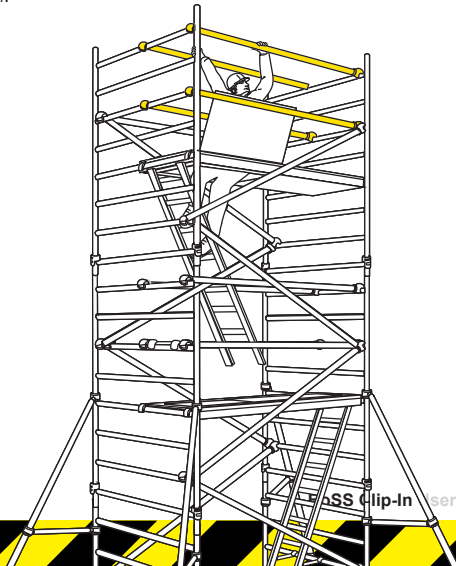

ASSEMBLY PROCEDURE

When building beyond a 4.2m platform height.

8 Continue to add pairs of end frames, diagonal braces and fit trapdoor decks and Clip in ladders as shown in the previous steps. At every platform level add horizontal braces as guardrails at 2 and 4 rungs above the platform. **Fit these guardrail braces from the protected trapdoor position. Do not climb onto the platform until it is fully guardrailed.**

Continue until the required height is reached. Position the fixed deck at the required platform height and fit a trapdoor deck alongside it as shown in **Stage 7**. Fit the guardrails as shown in **Stage 7**.

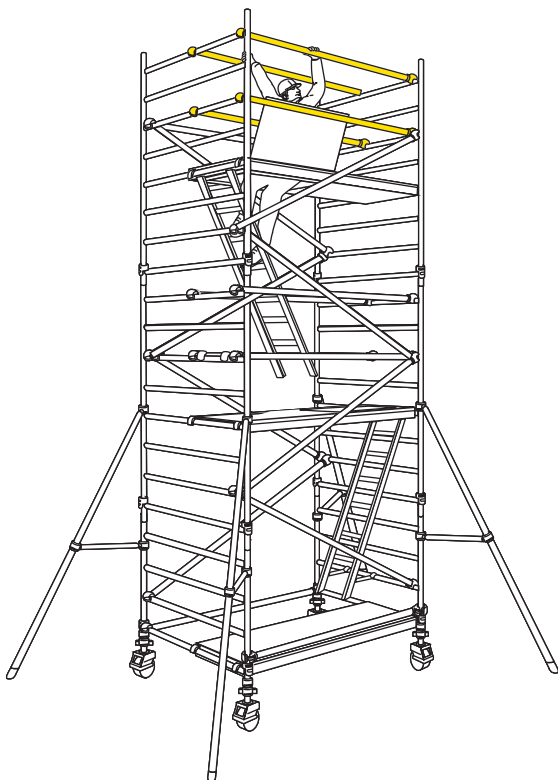

ASSEMBLY PROCEDURE

- 9** Fit toeboards (see Instructions on page 26).
The tower is now complete.

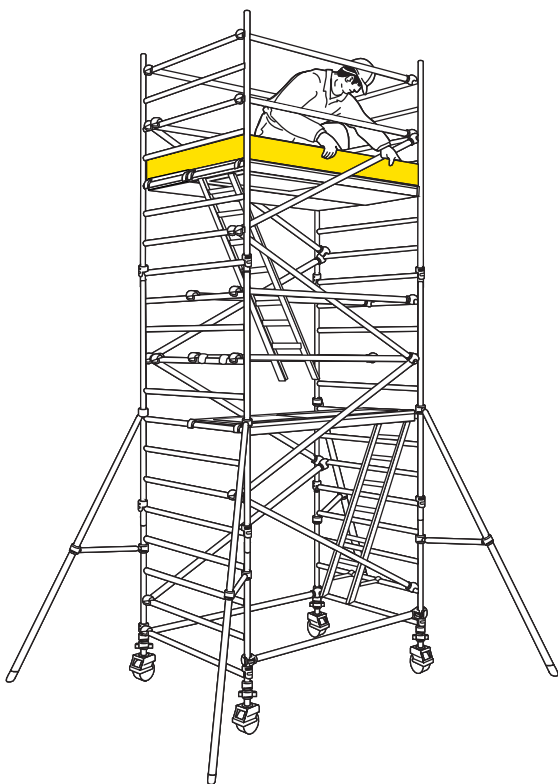

DISMANTLING PROCEDURE

- 10** To take down the tower reverse the building sequence. When removing guardrail braces, unlock the claws furthest from the trapdoor and then return immediately to the protected position within the trapdoor. You may then unlock the claws at the other ends of the Guardrails to remove them from the tower.

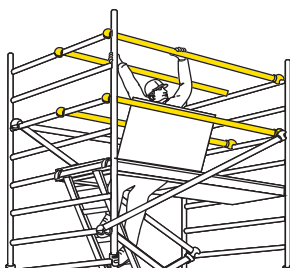

Toeboards

Mobile Towers - 3T Method

FITTING TOEBOARDS

Lock yellow plastic toeboard clips over rung and deck claw as shown. Position as (A) on right hand deck claw. On other side of the working platform, position the clip as (B). Place 25mm thick toeboards into slots in toeboard clips as shown.

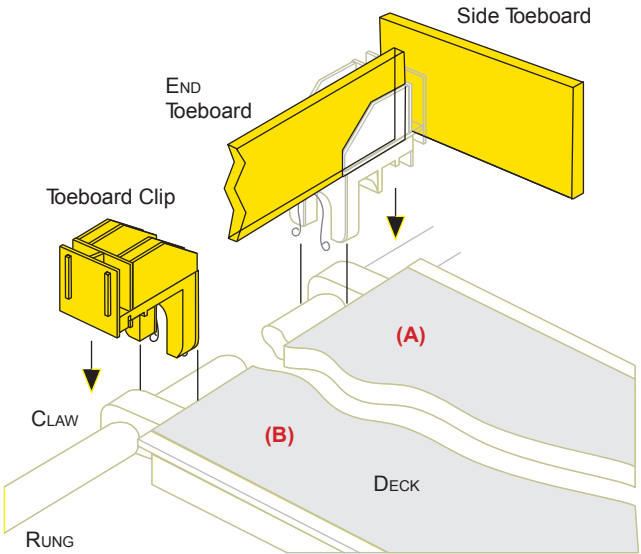

STABILISERS AND OUTRIGGERS

Mobile Towers - 3T Method

STABILISERS

Attach one stabiliser to each corner of the tower as shown. Ensure stabiliser feet are equally spaced to form a square.

SP10 and SP15 telescopic stabilisers must always be fully extended.

Position the lower clamp so that the lower arm is as close to the horizontal as possible. Adjust the position of the top clamp to ensure the stabiliser foot is in firm contact with the ground. Ensure clamps are secure.

Stabilisers are used when the tower is to be moved occasionally frequent movement will require mobile outriggers.

When moving the tower, adjust the top clamps to lift the four stabiliser feet a maximum of 25mm off the ground and then unlock the castor brakes. After moving ensure all four stabiliser feet are repositioned in firm contact with the ground.

STABILISER DIMENSIONS

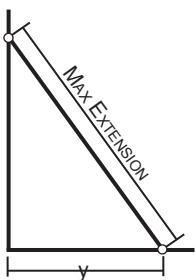

	y
SP7	1227
SP10	2241
SP15	2757

OUTRIGGERS

FOR INFORMATION ON MOBILE OUTRIGGERS PLEASE CONSULT YOUR SUPPLIER.

YOUNGMAN

INNOVATIVE WORK AT HEIGHT SOLUTIONS

For further information regarding this or any other products or services please contact :

Youngman are members of:



Youngman Group Ltd

The Causeway, Maldon, Essex,
CM9 4LJ,
United Kingdom

t +44 (0)1621 745900

f +44 (0)1621 859845

e sales@youngmangroup.com

youngmangroup.com