



BoSS Ladderspan incorporating BoSS Cam-Lock Advance Guardrail

Mobile aluminium tower
with 1450/850 frames

Contents

Safety First	2
Safety Checklist	8
Quantity Schedules	9
Assembly and Dismantling Procedure	15
Toeboards	23
Stabilisers and Outriggers	24

Safety First

INTRODUCTION

Please read this guide carefully. Please note that diagrams are for illustrative purposes only. User guides are also available to download from our website at youngmangroup.com

BoSS mobile aluminium towers are light-weight scaffold towers used throughout the building and construction industry for both indoor and outdoor access solutions where a stable and secure platform is required. Ideal for maintenance and installation work or short-term access, the highly versatile towers provide a strong working platform for a variety of heights.

This User Guide provides you with step by step instructions to ensure your system is erected easily and safely, using the AGR (Advance Guard Rail) method.

The law requires that personnel erecting, dismantling or altering towers must be competent. Any person erecting a Youngman BoSS mobile tower must have a copy of this guide. For further information on the use of mobile access and working towers consult the PASMA operators code of practice.

If you need further information, design advice, additional guides or any other help with this product, please contact Youngman on +44 (0)1621 745900 email us at sales@youngmangroup.com or you can visit www.youngmangroup.com to download further information.

COMPLIANCES

The BoSS Ladderspan aluminium system has been designed, tested, approved and certified to EN 1004: 2004 Class 3



Instruction Manual EN 1298-IM-EN

PREPARATION AND INSPECTION

Inspect the equipment before use to ensure that it is not damaged and that it functions properly. Damaged or incorrect components shall not be used.

Safety First

SAFE USE

- Check that all components are on site, undamaged and that they are functioning correctly – (refer to Checklist and Quantity Schedules in the user guide). Damaged or incorrect components shall not be used.
- Check ground on which tower is to be erected and moved is capable of supporting the tower.
- The safe working load is 275 kgs (606lbs), per platform level, uniformly distributed up to a maximum of 950kgs (2100lbs), per tower (including self weight).
- Towers must only ever be climbed from the inside and using the ladder directly below the trap door
- It is recommended that towers should be tied to a solid structure when left unattended.
- Only use the adjustable legs to level the tower and not to gain extra height. Adjustable legs should only ever be extended to minimum amount required to level the tower.

LIFTING OF EQUIPMENT

- Tower components should be lifted using a reliable lifting material (e.g. strong rope), employing a reliable knot (e.g. clove hitch), to ensure safe fastening and always lift within the footprint of the tower.
- Assembled mobile towers should not be lifted with a crane or other lifting device.

Safety First

STABILISERS / BALLAST

- Stabilisers or outriggers and ballast weights shall always be fitted when specified.
- The Quantity Schedules show the recommended stabilisation. In circumstances where there is restricted ground clearance for stabilisers/outriggers, contact your supplier for advice. Ballast must be of solid materials (i.e. not water or loose sand) and should not be positioned to overload individual legs. Ballast should be secured against accidental removal where practicable, and be placed on an appropriate platform positioned on the lowest rung of the bottom frame

Movement

Movement of the tower is strictly prohibited if any material, equipment or persons are on any of the platforms

- Check that the route of movement is clear and free from obstacles, hazards* or voids and the floor is capable of supporting the weight of the tower
- Do not move any tower structure in wind speeds over 7.7m per second (17mph). See page 5 of this user guide for wind speed guidance
- Dismantle the tower to a maximum height of 4m
- If stabilisers are fitted, raise them a maximum of 25mm above ground level (to clear uneven ground) and clamp tight.
- Check that the tower structure is secure and safe to move.
- Restrain the tower from unintentional movement and unlock all four castors.
- Move tower using manual effort only, applied at the base.
- Re-lock all four castors and re-position stabilisers (if fitted) as per this user guide.
- Using a spirit level, check tower is level and vertical as in step 4, setting the adjustable legs as required.
- Do not use adjustable legs to increase the overall height of the tower.
- Rebuild the tower (by competent person) to the intended working height.
- Inspect completed tower (by competent person) and record inspection.

NOTE: The work at height recommendations (reg 12 (2)) require that where the safety of work and equipment depends on how it is installed or assembled, it is not used after installation or assembly in any position unless it has been inspected in that position.

* Include electrical hazards, moving machinery, access restrictions, overhead cables etc.

Safety First

DURING USE

- Beware of high winds in exposed, gusty or medium breeze conditions. We recommend that in wind speeds over 7.7 metres per second (17 mph), cease working on the tower and do not attempt to move it. If the wind becomes a strong breeze, expected to reach 11.3 metres per second (25 mph), tie the tower to a rigid structure. If the wind is likely to reach gale force, over 18 metres per second (40 mph), the tower should be dismantled.

Wind Description	Beaufort Scale	Beaufort No.	Speed in m.p.h	Speed in m/sec
Medium Breeze	Raises dust and loose paper, twigs snap off	4	8-12	4-6
Strong Breeze	Large branches in motion, telegraph wires whistle	6	25-31	11-14
Gale Force	Walking is difficult	8	39-46	17-21

- Beware of open ended buildings, which can cause funnelling effect.
- Do not abuse equipment. Damaged or incorrect components shall not be used.
- Raising and lowering components, tools, and/or materials by rope should be conducted within the tower base. Ensure that the safe working load of the supporting decks and the tower structure is not exceeded.
- The assembled tower is a working platform and should not be used as a means of access or egress to other structures.
- Beware of horizontal forces (e.g. power tools) which could generate instability. **Maximum horizontal force 20 kg.**
- The stairway towers, featuring an inclined staircase access, are for frequent use by personnel carrying tools and/or materials.
- Mobile towers are not designed to be suspended - please refer to your supplier for advice.
- Do not use boxes or stepladders or other objects on the platform to gain extra height.

Safety First

TIES

- Ties should be used when the tower goes beyond its safe height, beyond the limits of the stabilisers/ outriggers, or if there is a danger of instability. They should be rigid, two way ties fastened to both uprights of the frame with load-bearing right angled or swivel couplers. Only couplers suitable for the 50.8mm diameter tube of the tower should be used. Ideally, ties should be secured to both faces of a solid structure by means of anchorages.
- The tie frequency may vary depending on the application, but they should, at a minimum, be every 4 metres height.
- For further information on tying-in a tower please contact your supplier or Youngman.

MAINTENANCE - STORAGE - TRANSPORT

- All components and their parts should be regularly inspected to identify damage, particularly to joints. Lost or broken parts should be replaced, and any tubing with indentation greater than 5mm should not be used and put to one side for repair by the manufacturer. Adjustable leg threads should be cleaned and lightly lubricated to keep them free running.
- Brace claws, frame interlock clips, trapdoor latches and platform windlocks should be regularly checked to ensure they lock correctly.
- Refer to the BoSS Inspection Manual and poster for detailed inspection and maintenance advice
- Components should be stored with due care to prevent damage.
- Ensure components are not damaged by excessive strapping forces when transported.

Safety First

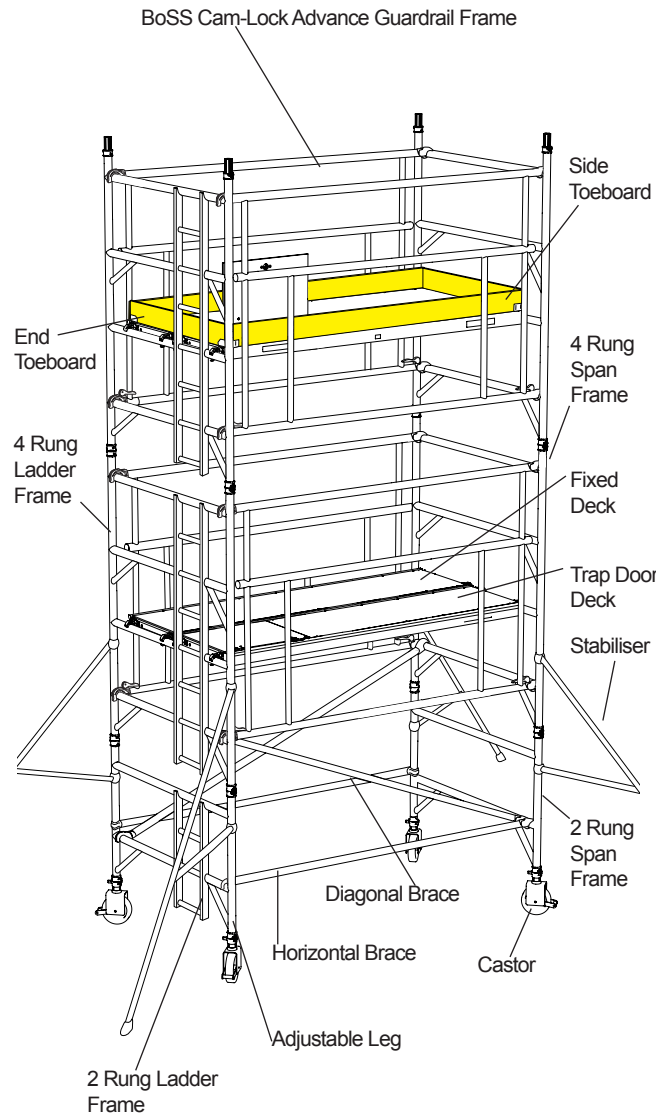

Safety Checklist

Mobile Towers - AGR Method

CHECKLIST

Ensure all brace claws & cam locks operate and lock correctly prior to erection	✓
Inspect components prior to erection	✓
Inspect tower prior to use and after movement and as required by current legislation	✓
Tower upright and level	✓
Castors locked and legs correctly adjusted	✓
Diagonal braces fitted	✓
Stabilisers/outriggers fitted as specified	✓
Platforms located and windlocks on	✓
Toeboards located	✓
Check guardrails are fitted correctly. See illustration below.	✓

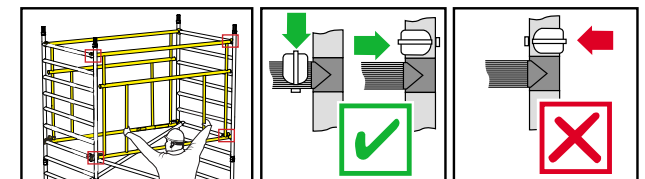

Ensure horizontal braces and guardrails are fitted correctly. Always fit as shown.

Refer to this checklist before using each time.

Quantity Schedule - 1450

BoSS Ladderspan incorporating BoSS Cam-Lock Advance Guardrail - 1450mm Wide x 1.8 & 2.5m long

	Internal or external use		Internal use only															
	Working Height (m)	Platform Height (m)	4.2	4.7	5.7	6.2	6.7	7.7	8.2	8.7	9.7	10.2	10.7	11.7	12.2	12.7	13.7	14.2
BoSS Ladderspan Cam Lock AGR 1450mm Wide x 1.8m & 2.5m long			4	4	4	4	4	4	4	4	4	4	4	4	4	4	4	4
AGRBUILD			4	4	4	4	4	4	4	4	4	4	4	4	4	4	4	4
Ø125mm/150mm/200mm Castor			4	4	4	4	4	4	4	4	4	4	4	4	4	4	4	4
Adjustable Leg			1	1	1	1	1	1	1	1	1	1	1	1	1	1	1	1
2 rung Ladder Frame (1.0m high x 1.45m wide)			1	1	1	1	1	1	1	1	1	1	1	1	1	1	1	1
2 rung Span Frame (1.0m high x 1.45m wide)			1	1	1	1	1	1	1	1	1	1	1	1	1	1	1	1
3 rung Ladder Frame (1.5m high x 1.45m wide)			1	1	1	1	1	1	1	1	1	1	1	1	1	1	1	1
3 rung Span Frame (1.5m high x 1.45m wide)			1	1	1	1	1	1	1	1	1	1	1	1	1	1	1	1
4 rung Ladder Frame (2.0m high x 1.45m wide)			1	1	1	1	1	1	1	1	1	1	1	1	1	1	1	1
4 rung Span Frame (2.0m high x 1.45m wide)			1	1	1	1	1	1	1	1	1	1	1	1	1	1	1	1
1.8m / 2.5m Trap Door Deck			1	2	2	2	2	2	2	2	2	2	2	2	2	2	2	2
1.8m / 2.5m Fixed Deck			1	2	2	2	2	2	2	2	2	2	2	2	2	2	2	2
1.8m / 2.5m Horizontal Brace			2	2	2	2	2	2	2	2	2	2	2	2	2	2	2	2
2.1m / 2.5m Diagonal Brace			2	2	2	2	2	2	2	2	2	2	2	2	2	2	2	2
1.8m / 2.5m Side Toe Board			2	2	2	2	2	2	2	2	2	2	2	2	2	2	2	2
1.2m End Toe Board			4	4	4	4	4	4	4	4	4	4	4	4	4	4	4	4
Toe Board Holder			2	2	2	2	2	2	2	2	2	2	2	2	2	2	2	2
1.8m / 2.5m Cam Lock AGR			4	4	4	4	4	4	4	4	4	4	4	4	4	4	4	4
SP7			4	4	4	4	4	4	4	4	4	4	4	4	4	4	4	4
SP10																		
SP15																		
Total Self Weight of Tower (Kg) -1.8m			133	151	192	196	214	254	271	289	329	334	351	392	396	414	454	459
Total Self Weight of Tower (Kg) -2.5m			150	173	221	226	248	296	313	336	384	389	411	459	464	487	534	539

Quantity Schedule

1450 Width Towers

NUMBER OF WORKING PLATFORMS ALLOWED

The MAXIMUM SAFE WORKING LOAD (the combined weight of the users, tools and materials) that may be placed on the tower is the total weight less the self weight of the tower. The total weight for the towers shown in the schedule is 950kg.

Example 1:

A 1450 ladderspan tower built using the AGR method with a 4.2m platform height and a platform length of 1.8m has a self weight of 196kg.

950kg total weight — 196kg self weight = 754kg maximum safe working load (users, tools and materials).

Example 2:

A 1450 Ladderspan tower built using the AGR method with a 11.7m platform height and a platform length of 2.5m has a self weight of 534kg.

950kg total weight — 534kg self weight = 416kg maximum safe working load (users, tools and materials).

For greater heights and loads, consult Youngman for guidance.

PLATFORM LOADING

On a 1450 AGR tower a platform comprises of two decks side by side. The maximum safe working load (the combined weight of the users, tools and materials) that may be placed on a platform is 275kg. This must be evenly distributed over both decks.

The quantities on page 9 will enable BoSS towers to be built safely and therefore comply with the requirements of the Work at Height Regulations. They include Advance Guardrail frames (AGR's) to all platforms, and toeboards for the top platform only. Additional toeboard sets will need to be added if any other levels are used as working platforms or for storage of materials.

EN 1004 requires platforms at least every 4.2m, and these measures will exceed that requirement.

Quantity Schedule

1450 Width Towers

BALLAST: Internal/External Use

There is no requirement for ballast on 1450 towers if using stabilisers as detailed in the table on page 9.

MOBILE OUTRIGGERS

MP16 outriggers can be used instead of SP15 stabilisers, as detailed below. Mobile outrigger kits comprise:

Mobile Outrigger Kit	
MP16 Mobile Outrigger	4
125/150/200mm Castor (Use same diameter castors as on tower)	4
250mm Adjustable leg	4
Plan Braces	4
The above components replace:	
SP15 Stabiliser	4

STABILISERS

To improve stability, larger stabilisers can be used at a lower level than shown in the table on page 9.

Angle of Stabiliser 1450 TOWER

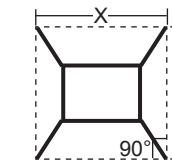

Double width 1450 Towers Dimension X

	Platform Length 1.8m	Platform Length 2.5m
SP7	X= 3351	X= 3629
SP10	X= 4789	X= 5100
SP15	X= 5520	X= 5838

Quantity Schedule - 850

BoSS Ladderspan incorporating BoSS Cam-Lock Advance Guardrail - 850mm Wide x 1.8 & 2.5m long

Boss Ladderspan Cam-Lock AGR 850mm Wide x 1.8m & 2.5m long	Internal or external use		Internal use only															
	Working Height (m)	Platform Height (m)	4.2	4.7	5.7	6.2	6.7	7.7	8.2	8.7	9.7	10.2	10.7	11.7	12.2	12.7	13.7	14.2
AGR BUILD			4	4	4	4	4	4	4	4	4	4	4	4	4	4	4	4
Ø125mm/150mm/200mm Castor			4	4	4	4	4	4	4	4	4	4	4	4	4	4	4	4
Adjustable Leg			1	1	1	1	1	1	1	1	1	1	1	1	1	1	1	1
2 rung Ladder Frame (1.0m high x 0.85m wide)			1	1	1	1	1	1	1	1	1	1	1	1	1	1	1	1
2 rung Span Frame (1.0m high x 0.85m wide)			1	1	1	1	1	1	1	1	1	1	1	1	1	1	1	1
3 rung Ladder Frame (1.5m high x 0.85m wide)			1	1	1	1	1	1	1	1	1	1	1	1	1	1	1	1
3 rung Span Frame (1.5m high x 0.85m wide)			1	1	1	1	1	1	1	1	1	1	1	1	1	1	1	1
4 rung Ladder Frame (2.0m high x 0.85m wide)			1	1	1	1	1	1	1	1	1	1	1	1	1	1	1	1
4 rung Span Frame (2.0m high x 0.85m wide)			1	1	1	1	1	1	1	1	1	1	1	1	1	1	1	1
1.8m / 2.5m Trap Door Deck			1	2	2	2	2	2	2	2	2	2	2	2	2	2	2	2
1.8m / 2.5m Horizontal Brace			2	2	2	2	2	2	2	2	2	2	2	2	2	2	2	2
2.1m / 2.7m Diagonal Brace			2	2	2	2	2	2	2	2	2	2	2	2	2	2	2	2
1.8m / 2.5m Side Toe Board			2	2	2	2	2	2	2	2	2	2	2	2	2	2	2	2
0.6m End Toe Board			4	4	4	4	4	4	4	4	4	4	4	4	4	4	4	4
Toe Board Holder			4	4	4	4	4	4	4	4	4	4	4	4	4	4	4	4
1.8m / 2.5m Cam Lock AGR			2	2	4	4	4	4	6	6	6	8	8	10	10	12	12	12
SP7			4	4	4	4	4	4	4	4	4	4	4	4	4	4	4	4
SP10																		
SP15																		
Total Self Weight of Tower (Kg) - 1.8m			113	131	155	159	177	213	217	235	259	278	281	305	309	327	351	355
Total Self Weight of Tower (Kg) - 2.5m			124	147	174	178	200	240	244	266	293	311	320	347	350	373	400	404

Quantity Schedule

850 Width towers

NUMBER OF WORKING PLATFORMS ALLOWED

The MAXIMUM SAFE WORKING LOAD (the combined weight of the users, tools and materials) that may be placed on the tower is the total weight less the self weight of the tower. The total weight for the towers shown in the schedule is 950kg.

Example 1:

An 850 Ladderspan tower built using the AGR method with a 4.2m platform height and a platform length of 1.8m has a self weight of 159kg.

950kg total weight — 159kg self weight = 791kg maximum safe working load (users, tools and materials).

Example 2:

An 850 Ladderspan tower built using the AGR method with a 10.2m platform height and a platform length of 2.5m has a self weight of 350kg.

950kg total weight— 350kg self weight = 600kg maximum safe working load (users, tools and materials).

For greater heights and loads, consult Youngman for guidance.

PLATFORM LOADING

On an 850 tower a platform comprises of a single deck only. The maximum safe working load (the combined weight of the users, tools and materials) that may be placed on a platform is 275kg, evenly distributed over the deck.

The quantities on **page 12**, will enable BoSS towers to be built safely and therefore comply with the requirements of the Work at Height Regulations. They include Advance Guardrail frames (AGR's) to all platforms, and toeboards for the top platform only. Additional toeboard sets will need to be added if any other levels are used as working platforms or for storage of materials.

EN 1004 requires platforms at least every 4.2m, and these measures will exceed that requirement.

Quantity Schedule

850 Width Towers

BALLAST: Internal/External Use

There is no requirement for ballase on 850 towers if using stabilisers as detailed in the table on **page 12**.

MOBILE OUTRIGGERS

MP16 mobile outriggers can be used instead of SP15 telescopic stabilisers respectively, as detailed below. Mobile outrigger kits comprise:

Mobile Outrigger Kit	
MP16 Mobile Outrigger	4
125/150/200mm Castor (Use same diameter castors as on tower)	4
250mm Adjustable leg	4
Plan Braces	4
The above components replace:	
SP15 Stabiliser	4

STABILISERS

To improve stability, larger stabilisers can be used at a lower level than shown in the table on **page 12**.

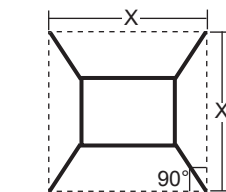

Single Width 850 Towers Dimension X

	Platform Length 1.8m	Platform Length 2.5m
SP7	X= 2994	X= 3201
SP10	X= 4458	X= 4734
SP15	X= 5195	X= 5485

Assembly Procedure

AGR Method

ASSEMBLY AND DISMANTLING PROCEDURES

When building a BoSS Tower:

- To comply with the Work at Height Regulations we show assembly procedures with platforms every 2 metres in height, and, the locating of guardrails in advance of climbing onto a platform to reduce the risk of a fall.
- All platforms feature double guardrails on both faces of either individual platforms or fully decked levels.
- All guardrails should be 1 and 2 rungs (0.5m and 1.0m) above platforms.
- Never stand on an unguarded platform positioned above the first rung of a tower. If your risk assessment shows it necessary, you may also need to guardrail platforms at this level.
- Always start building with the smallest height frames at the base of the tower:**

Platform Heights in Metres	Frame at base	1st Deck	1st AGR
2.2, 4.2, 6.2, 8.2, 10.2, 12.2	2 Rung	4th Rung	3rd Rung
2.7, 4.7, 6.7, 8.7, 10.7	3 Rung	1st Rung	4th Rung
3.7, 5.7, 7.7, 9.7, 11.7	2 + 3 Rung	3rd Rung	2nd Rung

Where all 3 frame heights are used in a tower, start with a 2 rung frames at the base, with the 3 rung frames next and the 4 rung frames on the top. Refer to the Quantity Schedules for detail.

Assembly Procedure

AGR Method

ASSEMBLY FOR 850 & 1450 TOWERS

Youngman recommend two persons are used to build BoSS Towers. **Above 4m height, it is essential that at least two persons are used. Only climb the tower from the inside.**

Always start building with the smallest height frames at the base of the tower:

Platform Heights in Metres	Frame at base	1st Deck	1st AGR
2.2, 4.2, 6.2, 8.2, 10.2, 12.2	2 Rung	4th Rung	3rd Rung
2.7, 4.7, 6.7, 8.7, 10.7	3 Rung	1st Rung	4th Rung
3.7, 5.7, 7.7, 9.7, 11.7	2 + 3 Rung	3rd Rung	2nd Rung

Where all 3 frame heights are used in a tower, start with 2 rung frames at the base, with the 3 rung frames next and the 4 rung frames on the top. Refer to the Quantity Schedules for detail. The procedure illustrated shows a 1450 tower starting with 2 rung frames and a platform height of 4.2m. If building an 850 tower, the following method can be used with single decks at all levels.

- Push 4 castors into 4 adjustable legs. Adjust leg so that not more than 50mm of thread is visible below the nut. Insert adjustable legs into 2 end frames (one ladder and one span frame) as shown. Lock castor brakes. Base plates can be fitted to adjustable legs if it is not necessary to move the tower.

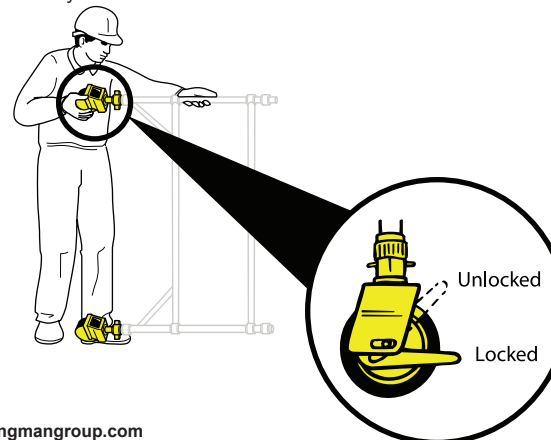

Assembly Procedure

- Fit one horizontal brace (red) onto the vertical of an end frame, just above the bottom rung, with the claw facing outwards.

Note: Check all claws are primed (unlocked) before fitting

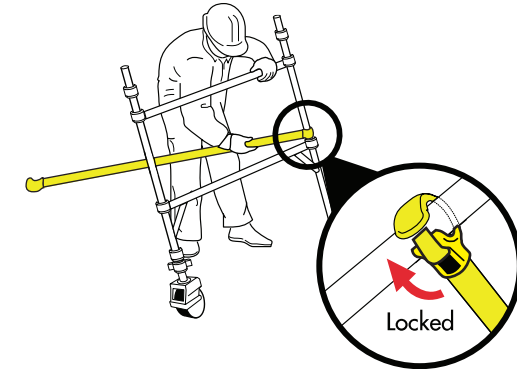

- Position the second end frame as shown and fit the other end of the horizontal brace on to the vertical, just above the bottom rung. Fit a second horizontal brace on the bottom rungs on the other side of the frames to square the tower.

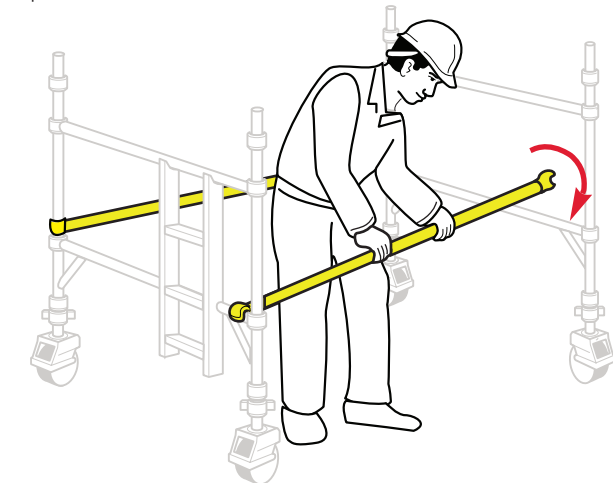

NOTE: Check all brace claws are positively locked after fitting.

Assembly Procedure

4 Fit 2 additional end frames ensuring ladder sections line up and check the frame interlock clips are engaged. Fit 2 diagonal braces (blue) in opposing directions, from the 1st rung to the 3rd rung on the opposing side. Diagonal braces should be positioned approx 80mm inboard of the frame verticals. Ensure the frames are vertical and level by checking with a spirit level and setting the adjustable legs as required.

IMPORTANT – Only use the adjustable legs to level the tower and not to gain extra height. Adjustable legs should only ever be extended to minimum amount required to level the tower.

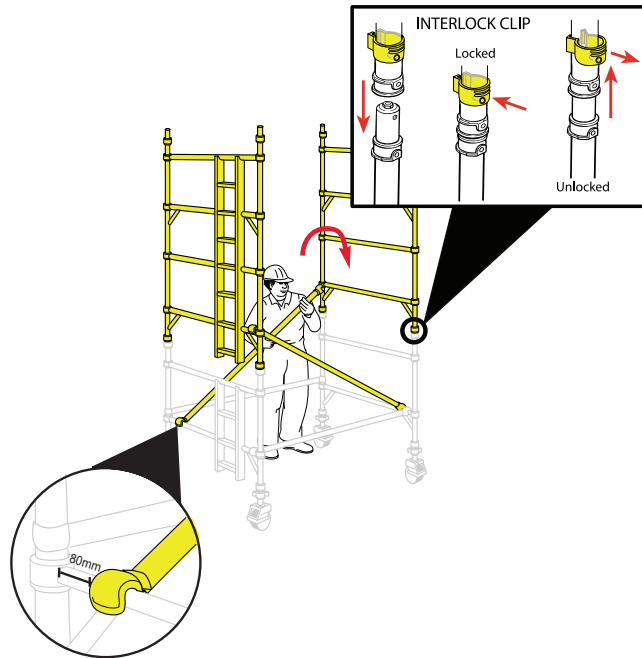

Assembly Procedure

5 Fit a Cam-Lock AGR on each side of the tower. The bottom of the AGR must be fitted to the 3rd rung of the tower, as shown. The AGR should be placed up against the end frame verticals. Secure AGR frame by pulling the locking handle firmly down onto the lower horizontal tube of the AGR (locked position)

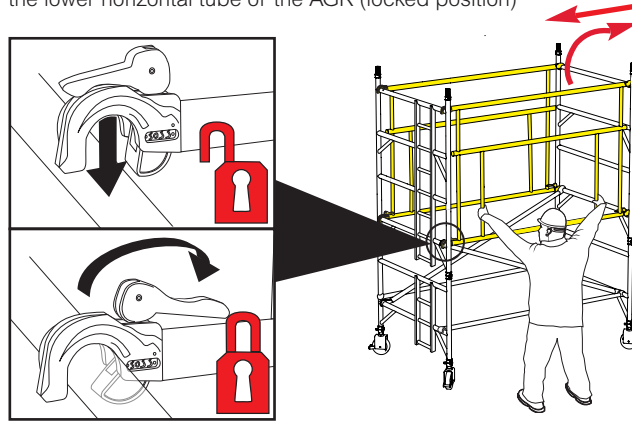

6 Fit the stabilisers (See notes on page 24) if building higher – or on single width (850mm) towers. If required, fit a temporary deck on the lowest rungs of the tower. Fit a trapdoor deck on the 4th rung with trapdoor adjacent to the ladder. Ensure the trapdoor is positioned with the hinges towards the outside of the tower as shown. Fit a fixed deck next to the trapdoor deck on the 4th rung. (If fitted, remove the temporary deck from the lowest rungs.) The platform is now complete. Always climb the ladder below the trapdoor and always on the inside of the tower.

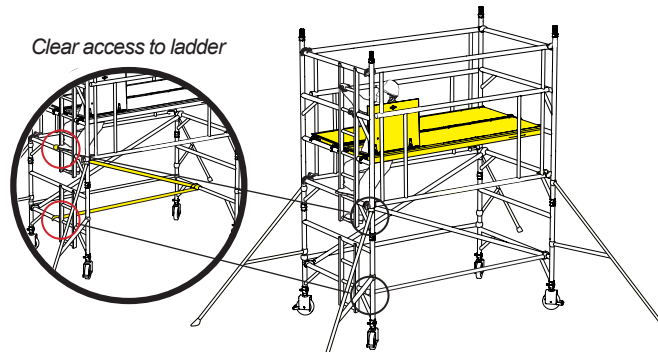

If clear access to the ladder is required, braces may be re-positioned as shown. Reposition braces to original location before moving tower.

Assembly Procedure

7 Fit two additional end frames, ensuring the ladder sections line up. Check interlock clips are engaged

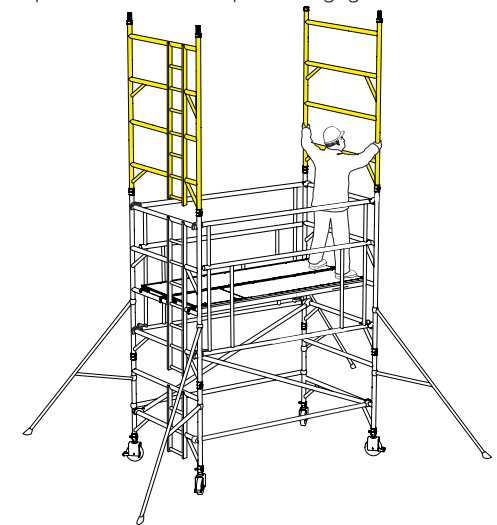

8 Fit 2 more AGR's to the end frames, with the top claws on the 10th rungs, lock the AGR's in place as in step 5. Fit a trapdoor deck on the 8th rung, with the trapdoor in line with the one below. Place a fixed deck on the 8th rung next to the trapdoor deck. The tower now has a platform height of 4.2m. If finishing at this height, move on to step 10. If greater platform height is required, repeat steps 7 and 8 until desired height is achieved.



Assembly Procedure

- 9** Continue to add pairs of end frames, AGR's and decks as shown in previous steps, until the required height is reached



Assembly Procedure

- 10** Fit toeboards (see Instructions on page 23). The tower is now complete.

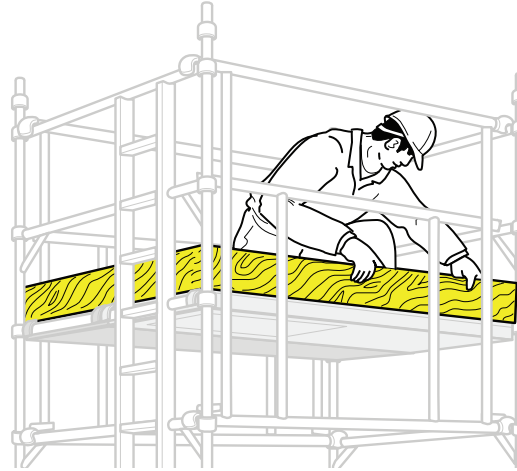

Dismantling Procedure

- 11** To dismantle the tower reverse the building sequence, i.e. remove decks, then AGR's, then end frames – always from the safety of the platform below.

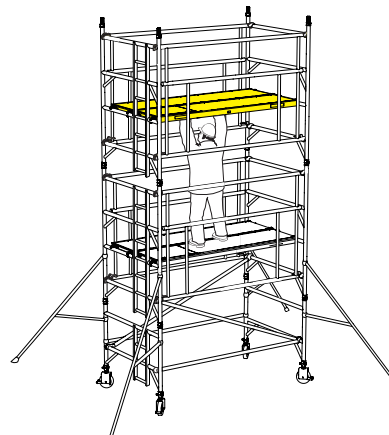

Toeboards

Mobile Towers - AGR Method

FITTING TOEBOARDS

Lock yellow plastic toeboard clips over rung and deck claw as shown. Position as (A) on right hand deck claw. On other side of the working platform, position the clip as (B). Place 25mm thick toeboards into slots in toeboard clips as shown.

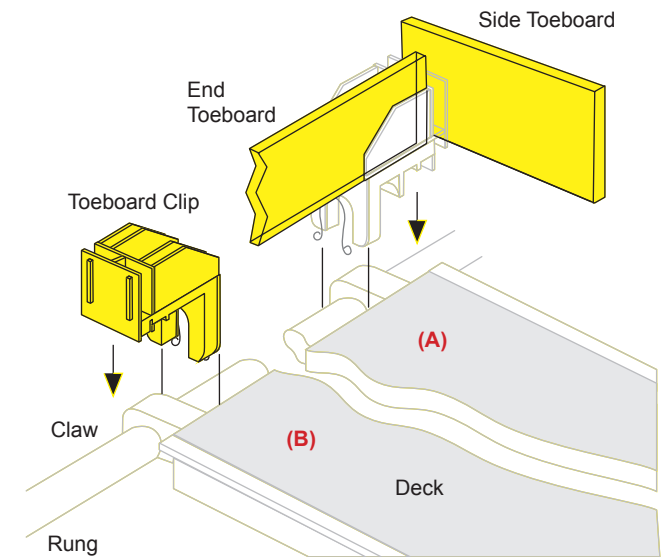

Stabilisers and Outriggers

Mobile Towers - AGR Method

STABILISERS

Attach one stabiliser to each corner of the tower as shown. Ensure stabiliser feet are equally spaced to form a square.

SP10 and SP15 telescopic stabilisers must always be fully extended.

Position the lower clamp so that the lower arm is as close to the horizontal as possible. Adjust the position of the top clamp to ensure the stabiliser foot is in firm contact with the ground. Ensure clamps are secure.

Stabilisers are used when the tower is to be moved occasionally, frequent movement will require mobile outriggers.

When moving the tower, adjust the top clamps to lift the four stabiliser feet a maximum of 25mm off the ground and then unlock the castor brakes. After moving ensure all four stabiliser feet are repositioned in firm contact with the ground.

STABILISER DIMENSIONS

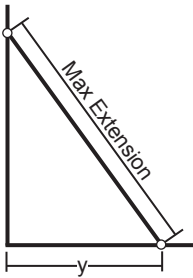

	y
SP7	1227
SP10	2241
SP15	2757

OUTRIGGERS

For information on mobile outriggers please consult your supplier.

YOUNGMAN

INNOVATIVE WORK AT HEIGHT SOLUTIONS

For further information regarding this or any other products or services please contact :

Youngman are members of:

Youngman Group Ltd

The Causeway, Maldon,
Essex, CM9 4LJ,
United Kingdom



t +44 (0)1621 745900

f +44 (0)1621 859845

e sales@youngmangroup.com

youngmangroup.com