

YOUNGMAN

INNOVATIVE WORK AT HEIGHT SOLUTIONS

BOSS X-Series

The ultimate range of push
around micro powered
access platforms



**MAINTENANCE
MANUAL**

Edition December 2011



EN 280

IP24



CONTENTS

SECTION 1 – DESCRIPTION, SPECIFICATION AND OPERATION	PAGE
1.1 Introduction	1
1.2 Intended use	1
1.3 Modifications	1
1.4 Terminology	2
1.5 Technical data	3
1.6 Engaging the brakes	4
1.7 Battery isolation switch	4
1.8 Battery charging	4
1.9 Handset control unit	5
1.10 Emergency lowering	5
SECTION 2 – SAFETY DURING MAINTENANCE	6
SECTION 3 – SERVICE ENGINEER ATTRIBUTES	6
SECTION 4 – COMPETENT PERSON FOR THOROUGH EXAMINATION ATTRIBUTES	6
SECTION 5 – PERIODICAL MAINTENANCE AND CHECKS	7
SECTION 6 – EXPLODED DRAWINGS AND PARTS LIST	9
SECTION 7 – ELECTRICAL SCHEMATIC	25
SECTION 8 – WIRING DIAGRAM	26
SECTION 9 – TILT SENSOR	27
SECTION 10 – HYDRAULIC SCHEMATIC	28
SECTION 11 – MACHINE LABELLING	29
SECTION 12 – STORAGE	30
SECTION 13 – TROUBLESHOOTING	30
SECTION 14 – DISPOSAL	30
SECTION 15 – MODIFICATIONS TO LATER BOSS X-SERIES MACHINES (REFER TO SERIAL NUMBERS AT START OF THIS SECTION)	31
APPENDIX – Example of report of thorough examination – LOLER 6 monthly inspection (UK only)	37

SECTION 1 – DESCRIPTION, SPECIFICATION AND OPERATION

1.1 INTRODUCTION

This Maintenance Manual provides the necessary information to enable maintenance to be undertaken on BoSS X-Series single person push around micro scissor lifts. Maintenance engineers should read and understand all the information contained in this manual before carrying out work on any BoSS X-Series machine.

This manual does not apply to BoSS X3 machines with serial numbers between YMG 11001 and 11300.

Additional copies of this Maintenance Manual may be obtained from Youngman Group Ltd., please see contact details in Section 1.3 on this page. The manual is also available to download from our website at youngmangroup.com.

1.2 INTENDED USE

BoSS X-Series machines have been designed to comply with the safety requirements of the European Machinery, Low Voltage and Electromagnetic Compatibility Directives and in accordance with the European Standard EN 280 Mobile Elevating Work Platforms – Design calculations – Stability criteria – Construction – Safety – Examinations and tests.

BoSS X-Series machines are intended to lift one person, plus essential tools and materials, to enable work to be undertaken at height. BoSS X-Series machines are designed for indoor use only and must be used on level ground which is able to support the weight of the machine and its maximum safe working load. Typical applications include maintenance, cleaning, painting, fit out work etc. at varying heights above ground level.

WARNING

The user must obtain the guidance and written approval of Youngman Group Ltd in the event of any special working methods or conditions which are outside those specified in this section.

1.3 MODIFICATIONS

No modifications shall be made to any BoSS X-Series machine unless Youngman Group Ltd. has given full written approval. If in doubt please contact us for advice:

Youngman Group Ltd.
The Causeway
Maldon
Essex
CM9 4LJ
United Kingdom

t +44 (0) 1621 745900
f +44 (0) 1621 859845
e sales@youngmangroup.com

1.4 TERMINOLOGY

- 1** Charging cables and guardrail tools tray
- 2** Forklift access, hoisting and transit strap points
- 3** Battery charging connection point
- 4** Battery charging indicator
- 5** Battery charge level indicator
- 6** Base unit emergency stop
- 7** Smooth roll castors with non marking tyres
- 8** Step up to platform
- 9** Fixed castors with auto braking applied as the platform is raised
- 10** Swivel castors with click on brakes
- 11** Emergency lowering release valve
- 12** Guardrails
- 13** Work platform
- 14** Scissor assembly
- 15** Hydraulic ram
- 16** Pressure loss valve
- 17** Fail-safe props
- 18** Chassis
- 19** Winching eye
- 20** Handset control unit
- 21** Instructions for Use storage tube
- 22** Access gate
- 23** Slip resistant deck incorporating lanyard point

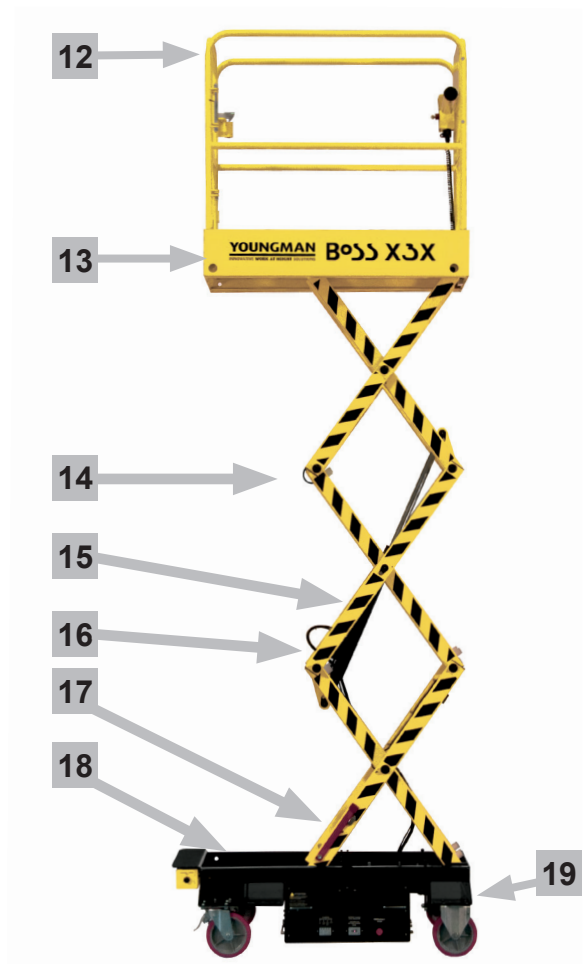

1.5 TECHNICAL DATA

	BoSS X3X	BoSS X3	BoSS X2
Rated load, manual forces and weight:			
Safe working load	240kg		
<i>equivalent to</i>	1 person (80kg) plus 160kg tools & materials		
Maximum allowable manual force	200N (interior use only)		
Maximum allowable chassis inclination	1.25°	1.5°	1.5°
Maximum allowable wind speed	0m/s		
Maximum load per wheel	450kg		
Machine weight	370kg	349kg	313kg
Maximum point loading	17.43kg/cm ²	16.83kg/cm ²	15.8kg/cm ²
Dimensions:			
Maximum platform height	3.2m	2.55m	2.01m
Minimum platform height	0.695m	0.695m	0.6m
Maximum safe working height	5.2m	4.55m	4.01m
Platform delay on descent height	1.87m	1.85m	1.4m
Platform width	0.57m		
Platform length	1.25m	1.05m	1.05m
Platform guardrail height	1.1m		
Toeboard height	0.15m		
Overall width	0.76m	0.7m	0.7m
Stowed height	1.8m	1.8m	1.7m
Stowed length	1.41m	1.21m	1.21m
Ground clearance	0.05m		
Electrical:			
Voltage	12V DC		
Motor	1.2kW	1.2kW	0.8kW
Battery (deep cycle/sealed gel)	12V/100Ah	12V/100Ah	12V/80Ah
Battery charger	Automatic multi voltage 110 and 240v		
Hydraulics:			
Maximum hydraulic pressure	225 bar		
Working pressure	150 bar		
Hydraulic fluid reservoir	2 litres		
Performance:			
Maximum number of lifts and descents on one charge:			
with 80kg platform load	>325	>430	>565
with 240kg platform load	>215	>225	>250
Ascent times:			
with 80kg platform load	15 seconds	12 seconds	10 seconds
with 240kg platform load	18 seconds	15 seconds	12 seconds
Descent times*:			
with 80kg platform load	21 seconds	17 seconds	15 seconds
with 240kg platform load	21 seconds	18 seconds	15 seconds

* Including 3 seconds for intermediate stop on descent

1.6 ENGAGING THE BRAKES

The BoSS X-Series machine is fitted with two braking systems:

- Fixed castors – these brakes are applied automatically as the platform rises
- Swivel castors – these brakes are engaged by the use of a foot pushing down on the lever as shown in the picture below. To release, push the foot under the lever and flick upwards. The swivel castors **MUST** be locked whenever the machine is stationary whether or not it is in use.



1.7 BATTERY ISOLATION SWITCH

The BoSS X-Series machine is provided with a key operated switch which is used to isolate the battery and therefore the electrical system, preventing unauthorised use.

To enable the electrical system, insert the key and turn clockwise, as shown below making sure the red emergency stop button is fully released.

Ensure that when the machine is not in use, the emergency stop button is depressed and the key removed.



1.8 BATTERY CHARGING

A battery charge level indicator is fitted to the BoSS X-Series machine. When the battery is fully charged the segment at the far right hand side of the display will be illuminated red, as shown in *figure 1* opposite.

When the second segment from the left is illuminated, as shown in *figure 2* below, it is time to put the BoSS X-Series machine on charge

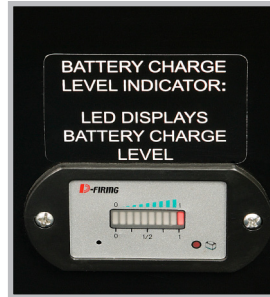

Figure 1

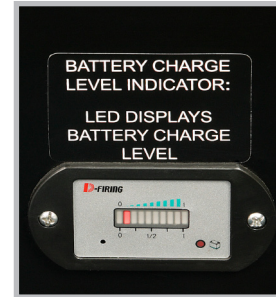

Figure 2

BoSS X-Series machines are fitted with low battery protection. If the battery level falls below 20% then the platform will not raise but can still descend.

The BoSS X-Series machine is fitted with an integral battery charger.

To charge the battery, follow the steps below:

- Depress the emergency stop button on the handset control unit and remove the key.
- Remove the cover from the charging connection point as shown in *figure 1* below.



Figure 1



Figure 2

- Connect either the mains or 110V transformer charging cable to the BoSS X-Series machine charging connection point, as shown in *figure 2* above. These cables are to be found in the charging cable and guardrail tools tray under the step up to the platform.
- Connect the charging cable to a suitable power supply (110V transformer or mains)
- Whilst the battery is charging to 80% of capacity the second light will be flashing as shown in *figure 1* on the following page and when the charging of the remaining 20% is underway the third light will begin flashing as indicated in *figure 2* on the following page.

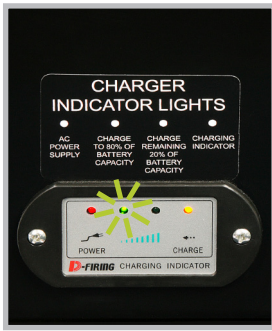

Figure 1

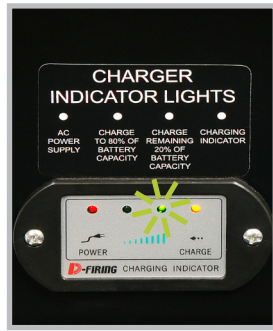

Figure 2

- f. When the battery is fully charged all four lights will illuminate after approximately 10 hours.

WARNING

BoSS X-Series machines must be charged where the ambient temperature is between 0 and 50°C.

1.9 HANDSET CONTROL UNIT

The handset control unit houses the platform raise and lower controls.

Pressing the 'UP' button raises the platform.
Pressing the 'DOWN' button lowers the platform

To avoid crushing or shearing hazards, an intermediate stop feature on lowering is fitted to activate when the platform reaches a base of work platform height from ground level of:

- BoSS X3X – 1.87m
- BoSS X3 – 1.85m
- BoSS X2 – 1.4m

This is a safety mechanism that reminds the operator to look around the machine to determine whether any persons are adjacent to the machine. After a time delay and when the operator is sure it is safe to do so, the 'DOWN' button can be depressed a second time to continue the descent.

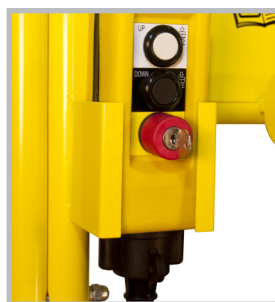

BoSS X-Series machines are fitted with an overload sensor system. If the platform load is exceeded the platform will not raise and the red LED indicator on top of the handset will illuminate as shown on the right.



1.10 EMERGENCY LOWERING

In the unlikely event of a power failure of the BoSS X-Series machine the platform can be lowered manually by use of the following procedure.

1. Turn the finger screw on the pressure loss valve anticlockwise until it will not turn any further as shown in *figure 1*.
2. Then, turn the emergency valve on the base unit anticlockwise until the platform begins to descend, as shown in *figure 2*. If you need to stop the descent simply turn this valve clockwise again.



Figure 1

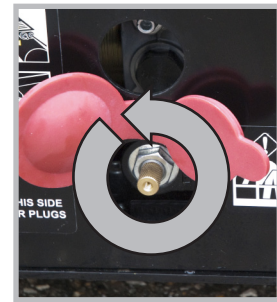

Figure 2

WARNING

Always ensure someone other than the operator is trained to perform this rescue.

SECTION 2 – SAFETY DURING MAINTENANCE

When carrying out maintenance on a BoSS X-Series machine with the platform elevated, always ensure that the maintenance props are deployed as shown in the picture below.

Maintenance Props



SECTION 3 – SERVICE ENGINEER ATTRIBUTES

The BoSS X-Series service engineer should:

- a. be physically fit and competent to carry out the work being undertaken;
- b. appear to be comfortable working at height when taken up in the work platform of a MEWP;
- c. have a responsible attitude;
- d. demonstrate an ability to learn;
- e. be able to communicate clearly with other personnel on site;
- f. be able to identify equipment;
- g. be able to demonstrate an understanding of and apply the information contained in this Maintenance Manual;
- h. be able to demonstrate that they can diagnose, rectify and record faults;
- i. be able to demonstrate an understanding and knowledge of how to carry out inspections (other than thorough examinations) and can make recommendations for the continued use of the equipment;
- j. be able to demonstrate an understanding of and apply company procedures;
- k. be able to demonstrate that they can operate the equipment safely;
- l. be able to demonstrate that they can carry out functional checks and setting procedures;
- m. be able to demonstrate knowledge of how to record all maintenance work carried out;
- n. be able to demonstrate the required knowledge and expertise of the BoSS X-Series machines for service and maintenance purposes;
- o. be undergoing a form of Continuous Professional Development.

SECTION 4 – COMPETENT PERSON FOR THOROUGH EXAMINATION ATTRIBUTES

The competent person carrying out a thorough inspection of a BoSS X-Series machine should:

- a. be physically fit;
- b. appear to be comfortable working at height when taken up in the work platform of a MEWP
- c. have a responsible attitude;
- d. demonstrate an ability to learn;
- e. be able to communicate clearly with other personnel on site;
- f. comply with EN 45004;
- g. be capable of detecting defects or weaknesses in the BoSS X-Series machine for the purpose of the thorough examination;
- h. have sufficient knowledge and experience to assess the importance of defects or weaknesses in the BoSS X-Series machine and identifying what actions need to be taken in order to rectify them. In particular they should be able to:
 - i. verify that the BoSS X-Series machine is operating as it is intended to in accordance with the Instructions for Use;
 - ii. identify defects or weaknesses which could compromise the use of the BoSS X-Series machine;
 - iii. specify the appropriate time scales within which identified defects or weaknesses need to be rectified;
 - iv. establish that defects identified in the previous report of thorough examination have received attention;
 - v. assess the correct function of all safety devices;
 - vi. check that warning notices are correctly fixed and legible; and where necessary specify any limitations to the use of the BoSS X-Series machine;
 - vii. carry out any testing required as part of the thorough examination;
 - viii. report on the findings of the thorough examination.

SECTION 5 - PERIODICAL MAINTENANCE AND CHECKS

The following checks should be undertaken at the intervals shown:

	Daily/pre-use	Monthly	6 monthly	Annually
Inspect structure	●	●	●	●
Check condition of castellated scissor nuts and split pin retainers	●	●	●	●
Inspect platform	●	●	●	●
Check condition of castors including tyres	●	●	●	●
Check castor brake function - auto braking on fixed castors and manually applied brakes on swivel castors.	●	●	●	●
Inspect hydraulic circuit for oil leaks	●	●	●	●
Check condition of hydraulic hose	●	●	●	●
Check condition of electrical cables	●	●	●	●
Check battery charge level	●	●	●	●
Check platform raise & lower functions including descent delay	●	●	●	●
Inspect platform full height cut off and descent delay switches	●	●	●	●
Inspect all safety labelling and machine plate	●	●	●	●
Check handset emergency stop	●	●	●	●
Check base unit emergency stop	●	●	●	●
Check emergency lowering function	●	●	●	●
Check hydraulic oil level	●	●	●	●
Check operation of descent alarm	●	●	●	●
Check operation of tilt sensor and alarm	●	●	●	●
Check electrical connectors		●	●	●
Grease scissor nipples		●	●	●
Grease platform and chassis roller nipples		●	●	●
Grease castor nipples		●	●	●
Check all castor nuts are fully tightened		●	●	●
Check integrity and tightness of all visible fixings eg screws, nuts and bolts			●	●
Replace hydraulic oil				●

Prior to the first use of a BoSS X-Series machine all daily/pre-use checks should be undertaken.

If the BoSS X-Series machine has been out of service for any length of time the six monthly checks referred to in the table above should be undertaken by an authorised, competent and suitably trained person.

The Lifting Operations and Lifting Equipment Regulations 1998 (LOLER) require that lifting equipment for lifting persons must be THOROUGHLY EXAMINED every six months (UK only).

Following any maintenance of a BoSS X-Series machine, a full test of the functionality should be undertaken to ensure the correct operation of the machine.

It is essential that only Youngman approved replacement parts are used when maintaining and servicing the BoSS X-Series machine. Failure to do so may result in an unsafe machine. Details on how to order replacement parts can be found by visiting youngmangroup.com or by calling +44 (0) 1621 745900.

You will need to provide our parts distributor with:

- Name of model ie BoSS X2, X3 or X3X
- Serial number to be found on the machine plate attached to the chassis of the machine
- Year of construction
- Date of purchase of machine
- Part number from this Maintenance Manual
- Description from this Maintenance Manual
- Quantity required
- Company invoice address
- Delivery address and contact number at this address
- Desired method of shipment

Lubrication

The recommended lubricant for use with the BoSS X-Series machines is standard machine grease and the lubrication points are shown in the pictures below.

Scissors

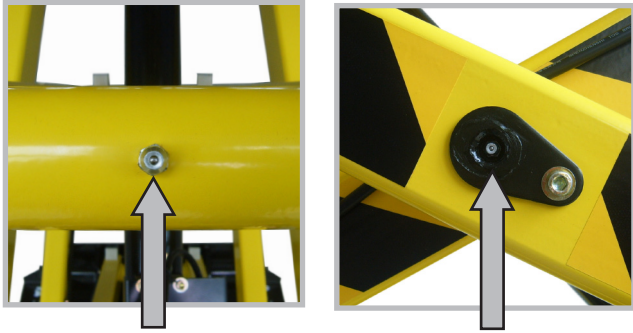

Scissor rollers

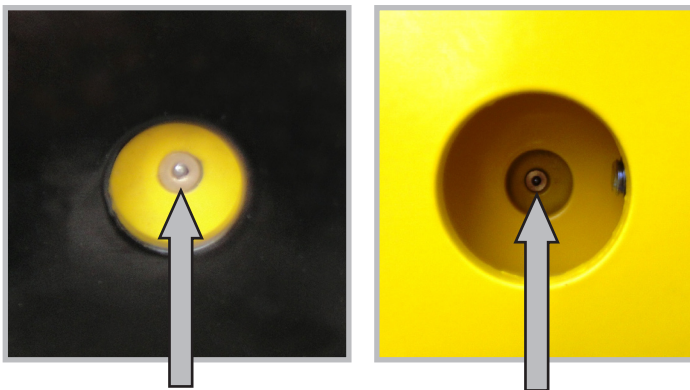

Hydraulic oil

The hydraulic oil used to top up the reservoir of the BoSS X-Series machine or when a complete oil change is required should be a VG 46 fully inhibited hydraulic oil manufactured in accordance with DIN 51524 Part 2.

VG 46 Hydraulic Oil

Appearance	Amber coloured oil
Relative density at 15 °C	0.87-0.89
Kinematic viscosity at 40 °C	41.4-50.6 cSt
Flash point (open cup) (°C)	>180
Pour point (°C)	-12

The hydraulic oil level should be checked daily and topped up as required. Following removal of the cap to the hydraulic reservoir, the oil as specified above should be poured from a small jug or through a funnel into the reservoir until the oil covers the aluminium plate just inside the reservoir, see *figure 1* opposite, and the cap replaced.

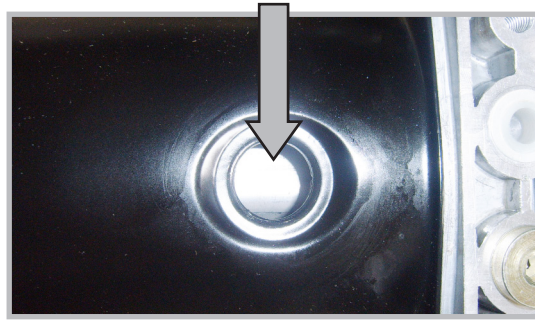

Figure 1

WARNING

Ensure the platform is fully lowered when checking the oil level.

Do not overfill the hydraulic oil reservoir and take care not to spill the oil on any of the surrounding machine components.

The hydraulic oil is changed as follows:

1. Ensure the platform is fully lowered.
2. Lift the machine with a forklift using the lateral forklift points and secure with safety props.
3. Slide out the component drawer of the machine.
4. Remove the red and black oil reservoir cap from the top of the reservoir.
5. Look under the drawer where you will see an M10 Allen bolt as shown below.

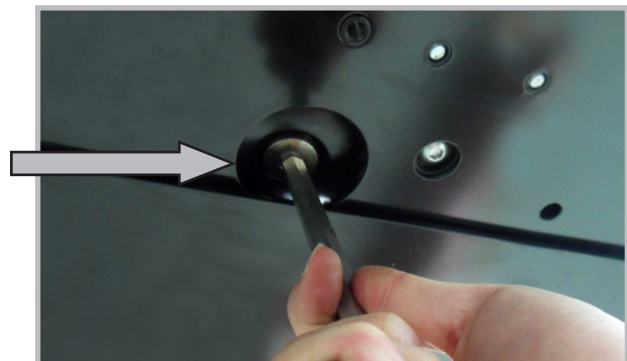

6. Undo the bolt and let the oil drain into an open top container which can hold a minimum of 2 litres. Dispose of the oil at an approved disposal facility.
7. Replace M10 bolt and refill reservoir until the aluminium plate at the opening to the reservoir is just covered.
8. Replace the reservoir cap.

SECTION 6 – EXPLODED DRAWINGS AND PARTS LIST

BoSS X3X Assembly

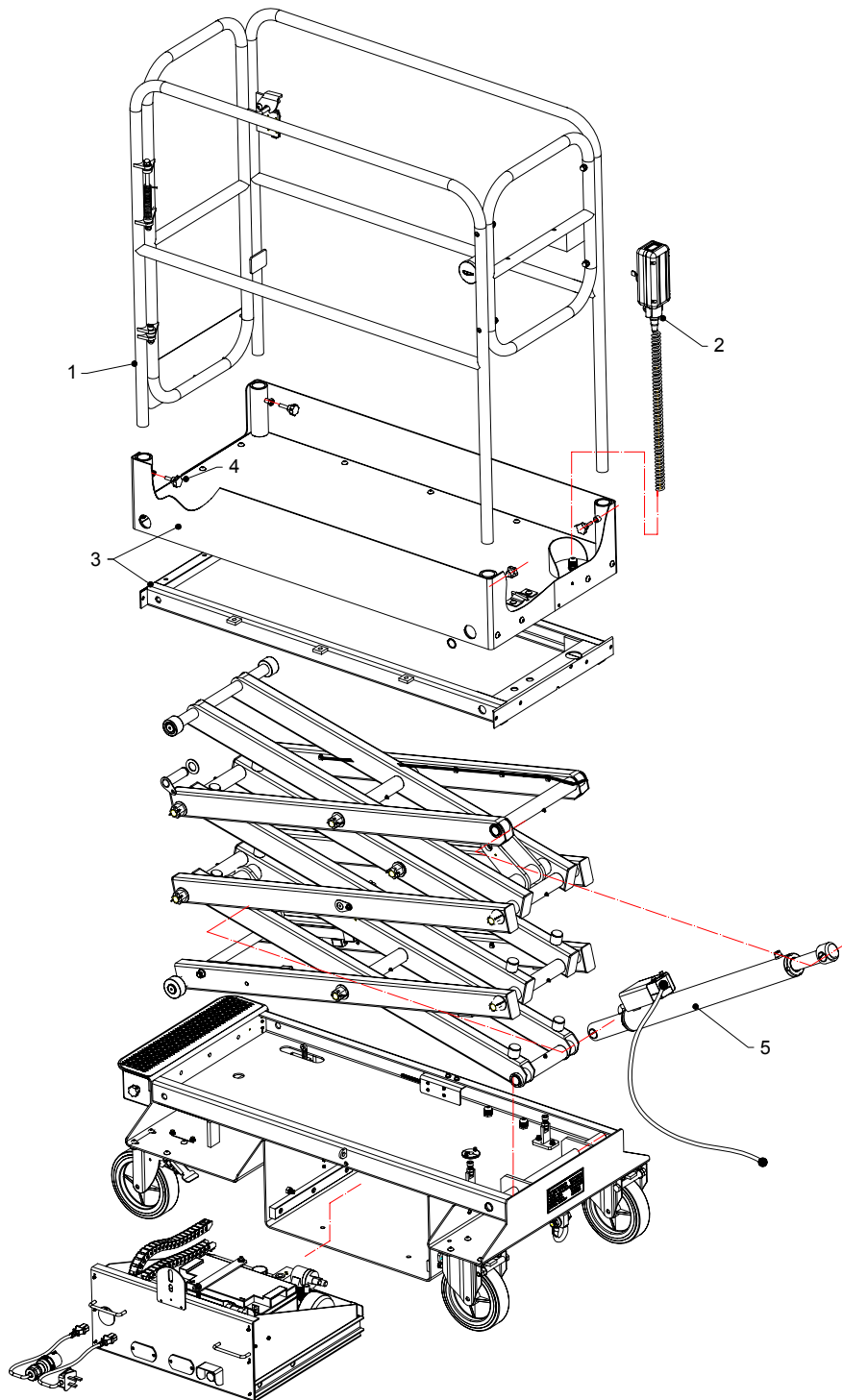

Item Ref	Part No.	Description	Qty.
1	83901000	Guardrail assembly	1
2	81908000	Handset controller assembly	1
3	83902000	Aluminium platform and steel runner	1
4	81902014	Handle screw with locking nut	4
5	83904000	Cylinder assembly X3X	1

BoSS X3 Assembly

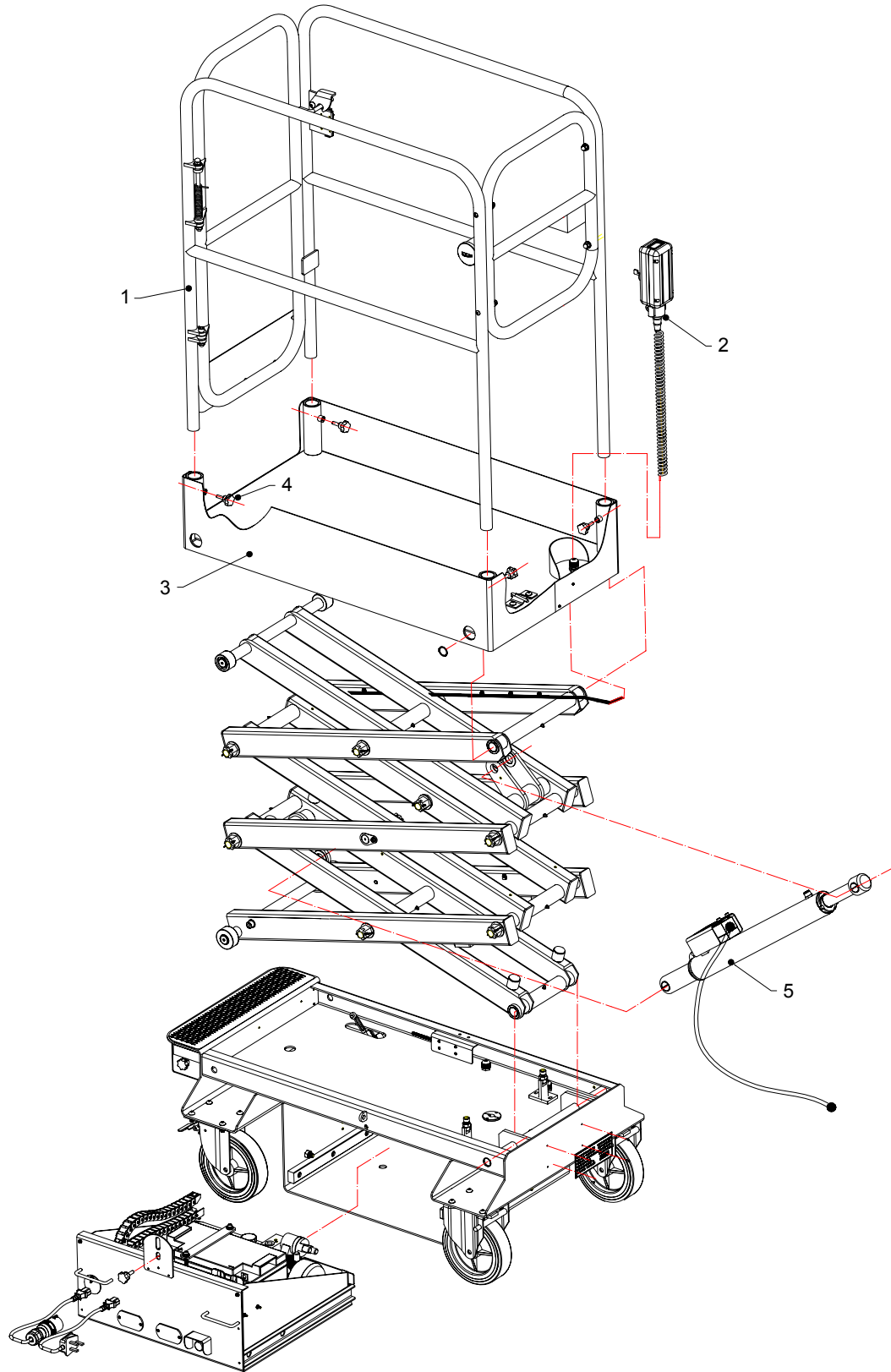

Item Ref	Part No.	Description	Qty.
1	81901001	Guardrail assembly	1
2	81908000	Handset controller assembly	1
3	81902001	Platform assembly	1
4	81902014	Handle screw with locking nut	4
5	81904000	Cylinder assembly X3	1

BoSS X2 Assembly

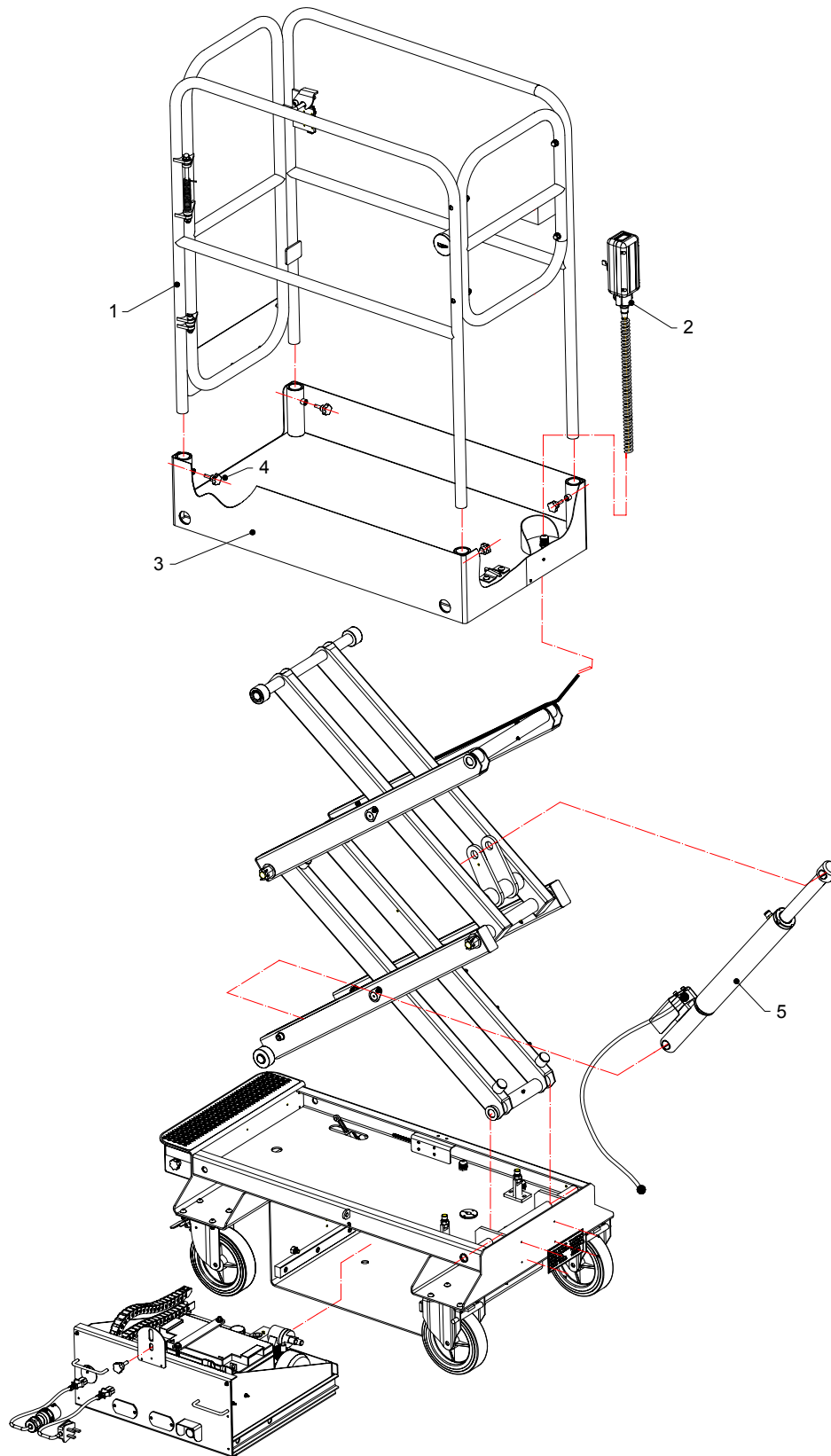

Item Ref	Part No.	Description	Qty.
1	82901001	Guardrail assembly	1
2	81908000	Handset controller assembly	1
3	82902001	Platform assembly	1
4	81902014	Handle screw with locking nut	4
5	82904000	Cylinder assembly X2	1

BoSS X3X/X3/X2 Guardrail Assembly

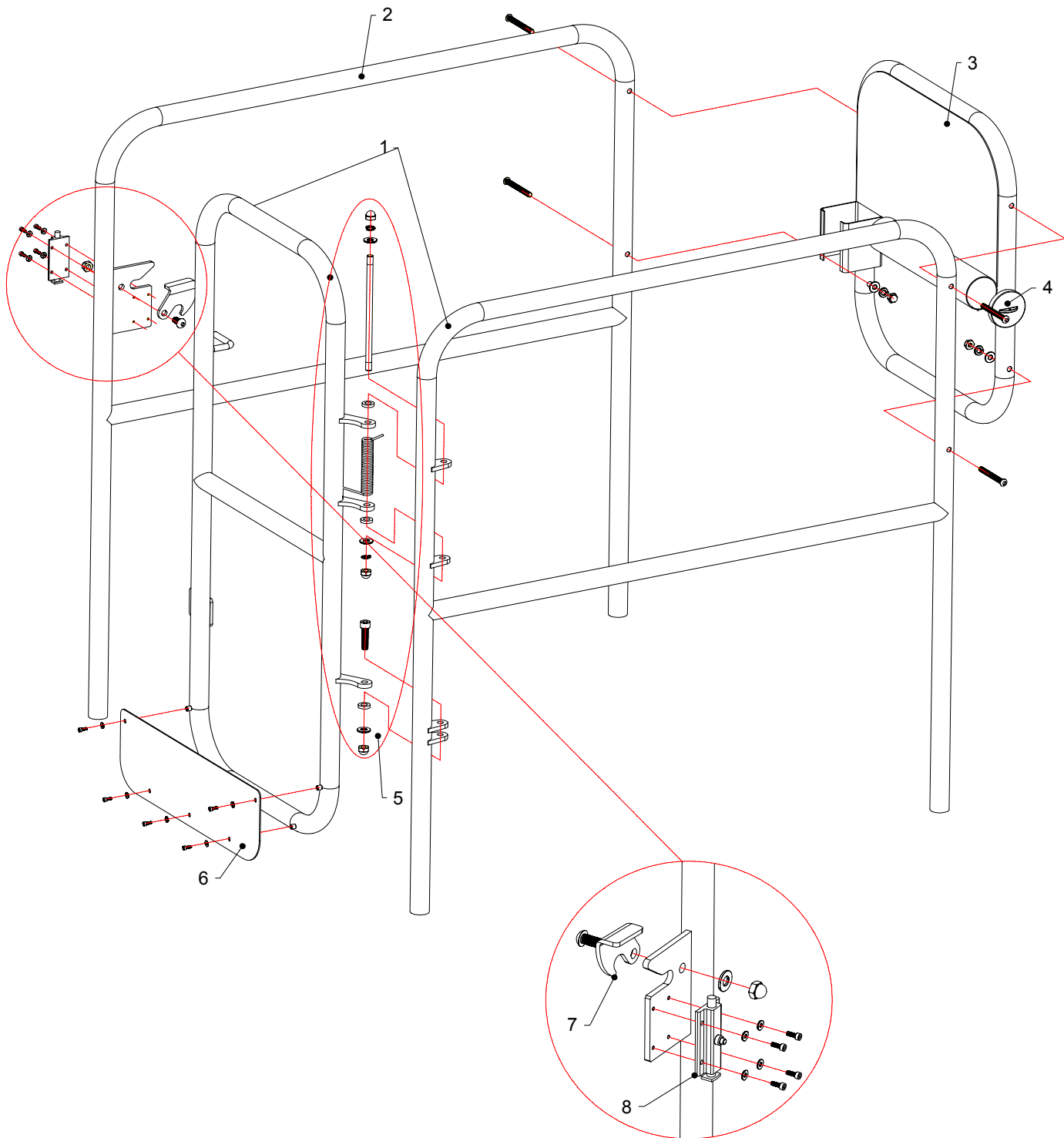

BoSS X3X/X3/X2 Guardrail Assembly continued

X3X Guardrail Assembly

Item Ref	Part No.	Description	Qty.
1	83801001	Right guardrail & gate assembly	1
2	83901003	Left guardrail assembly	1
3	83901007	Back guardrail assembly	1
4	81020071	Instruction tube cap	1
5	81801017	Gate hinge fixing kit	1
6	83901024	Gate toeboard with label	1
7	81020101	Gate latch	1
8	81122061	Transit gate lock	1

X3 Guardrail Assembly

Item Ref	Part No.	Description	Qty.
1	81801001	Right guardrail & gate assembly	1
2	81901005	Left guardrail assembly	1
3	81901007	Back guardrail assembly	1
4	81020071	Instruction tube cap	1
5	81801017	Gate hinge fixing kit	1
6	81901024	Gate toeboard with label	1
7	81020101	Gate latch	1
8	81122061	Transit gate lock	1

X2 Guardrail Assembly

Item Ref	Part No.	Description	Qty.
1	82801001	Right guardrail & gate assembly	1
2	81901005	Left guardrail assembly	1
3	82901007	Back guardrail assembly	1
4	81020071	Instruction tube cap	1
5	81801017	Gate hinge fixing kit	1
6	82901024	Gate toeboard with label	1
7	81020101	Gate latch	1
8	81122061	Transit gate lock	1

BoSS X3X/X3/X2 Handset Controller Assembly

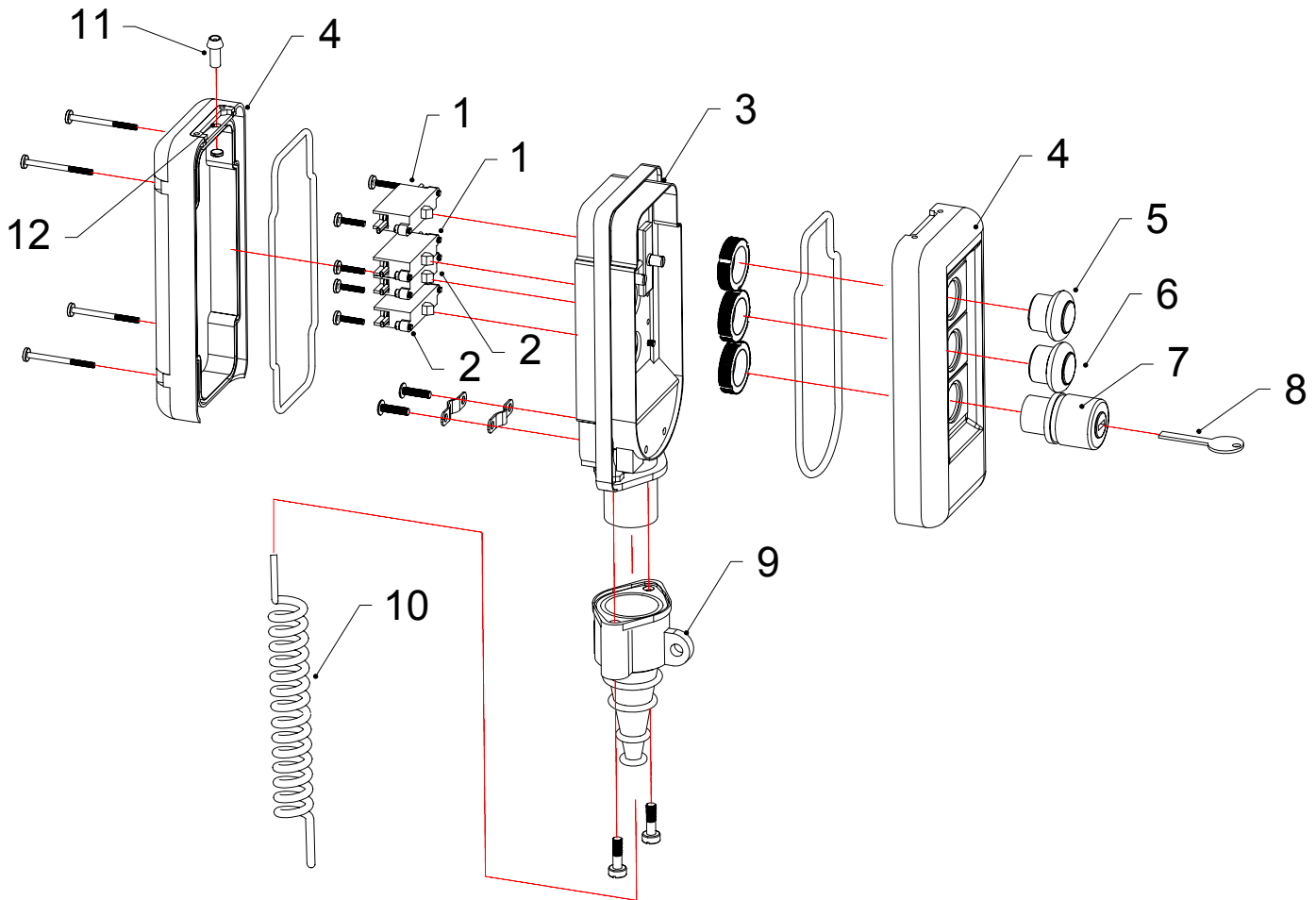

Item Ref	Part No.	Description	Qty.
1	81130041	Normally open switch	2
2	81130171	Normally closed switch	2
3	81130051	Main body	1
4	81130181	Front plate & back plate	1
5	81130081	Up button	1
6	81130091	Down button	1
7	81130101	Emergency stop	1
8	81801016	Key	1
9	81130131	Waterproof cover	1
10	81020121	Curly cable assembly	1
11	81801002	Overload light assembly	1
12	81911018	Overload label	1

BoSS X3X/X3 Scissor Assembly

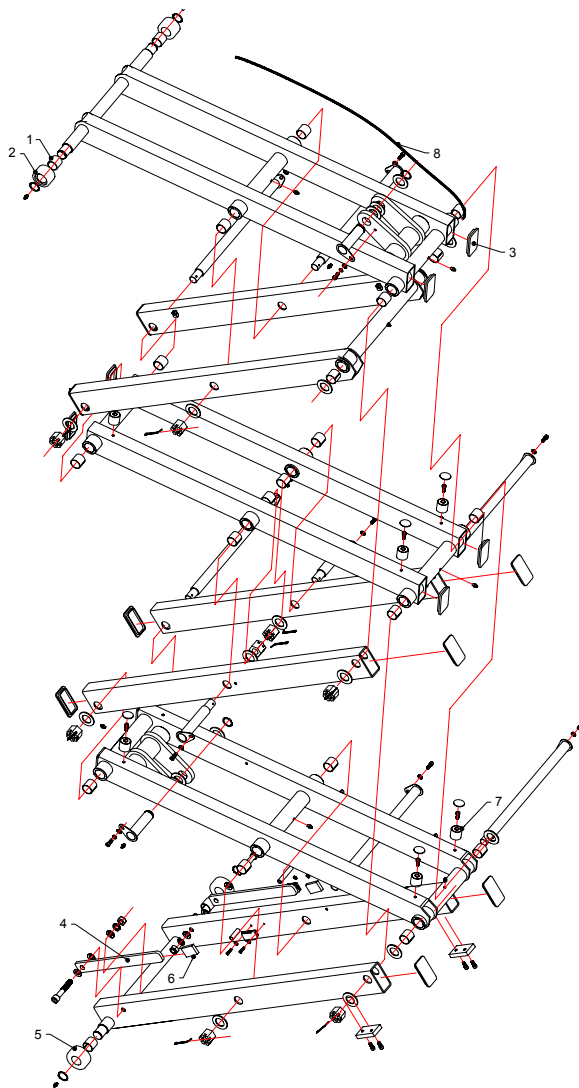

X3X Scissor Assembly

Item Ref	Part No.	Description	Qty.
1	81070091	Scissor bush	24
2	81070111	Platform roller	2
3	81200151	Scissor black end cap	16
4	81903041	Maintenance prop assembly	2
5	81903039	Base roller	2
6	81070131	Caps for maintenance props	2
7	81903037	Scissor pads	8
8	83905013	X3X scissor cable	1

X3 Scissor Assembly

Item Ref	Part No.	Description	Qty.
1	81070091	Scissor bush	24
2	81070111	Platform roller	2
3	81200151	Scissor black end cap	16
4	81903041	Maintenance prop assembly	2
5	81903039	Base roller	2
6	81070131	Caps for maintenance props	2
7	81903037	Scissor pads	8
8	81910028	X3 scissor cable	1

BoSS X2 Scissor Assembly

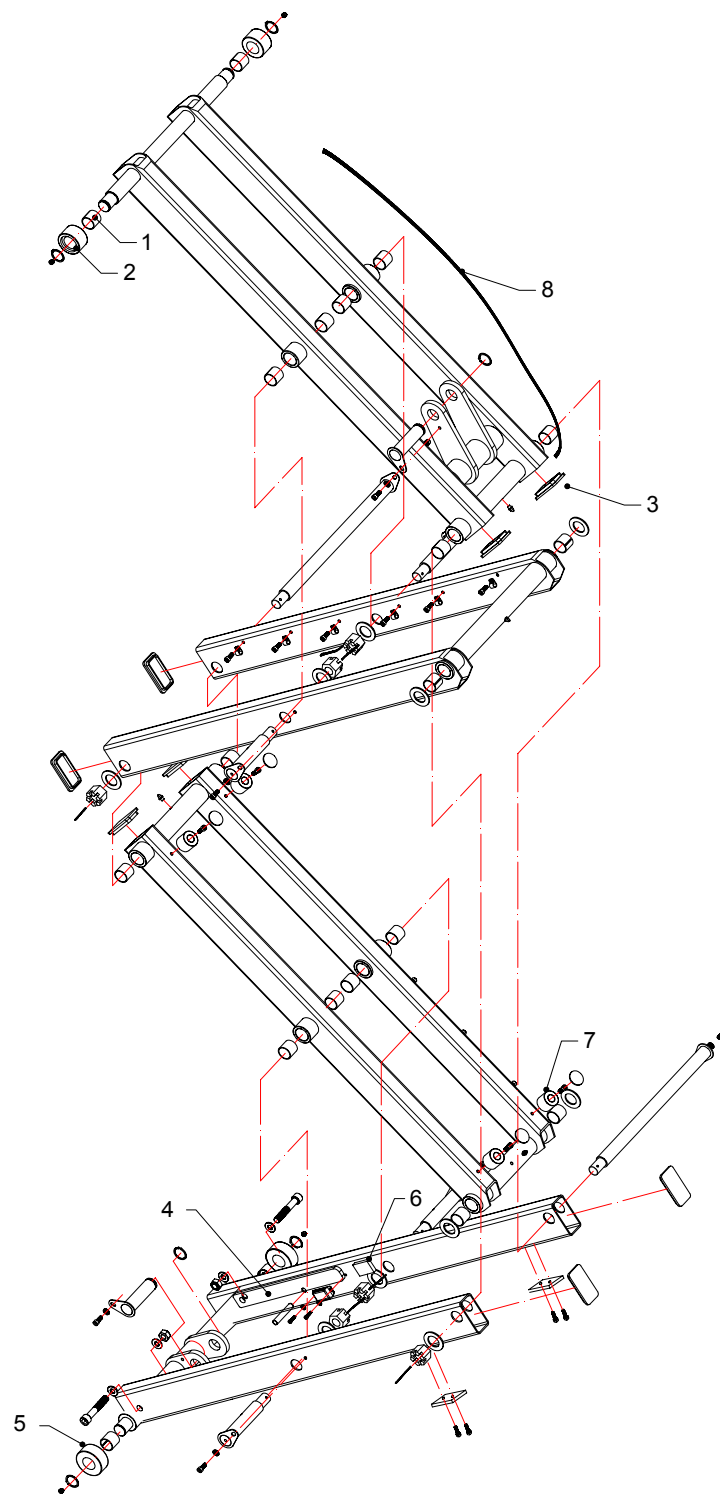

Item Ref	Part No.	Description	Qty.
1	81070091	Scissor bush	24
2	81070111	Platform roller	2
3	81200151	Scissor black end cap	8
4	81903041	Maintenance prop assembly	2
5	81903039	Base roller	2
6	81070131	Caps for maintenance props	2
7	81903037	Scissor pads	4
8	82905003	X2 scissor cable	1

BoSS X3X/X3 Hydraulic Cylinder Assembly

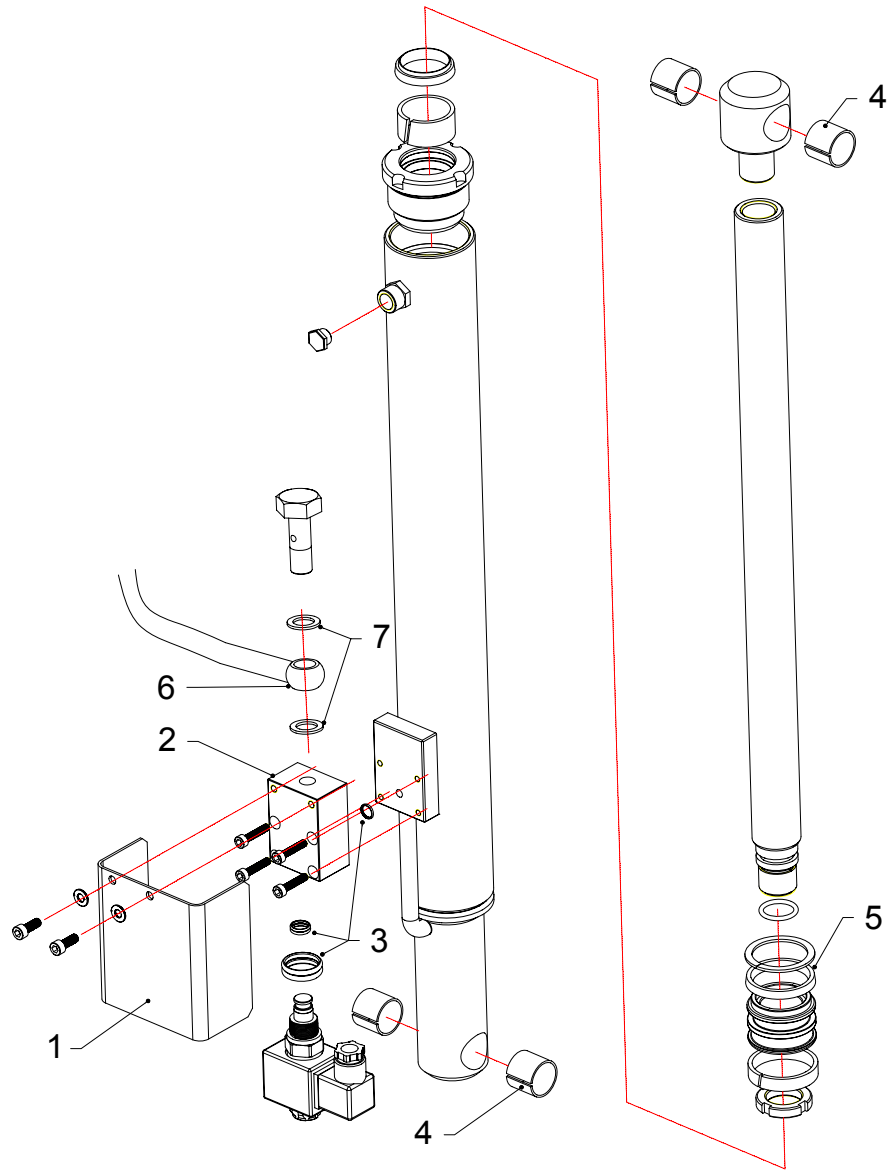

X3X Hydraulic Cylinder Assembly

Item Ref	Part No.	Description	Qty.
1	81904026	Pressure loss valve cover	1
2	81904006	Pressure loss valve	1
3	81801003	Pressure loss valve o-rings	1
4	81070091	Bush	4
5	81801004	Seal kit	1
6	83904002	X3X hydraulic hose	1
7	81904031	Pressure loss valve seal kit	1

X3 Hydraulic Cylinder Assembly

Item Ref	Part No.	Description	Qty.
1	81904026	Pressure loss valve cover	1
2	81904006	Pressure loss valve	1
3	81801003	Pressure loss valve o-rings	1
4	81070091	Bush	4
5	81801004	Seal kit	1
6	81904014	X3 hydraulic hose	1
7	81904031	Pressure loss valve seal kit	1

BoSS X2 Hydraulic Cylinder Assembly

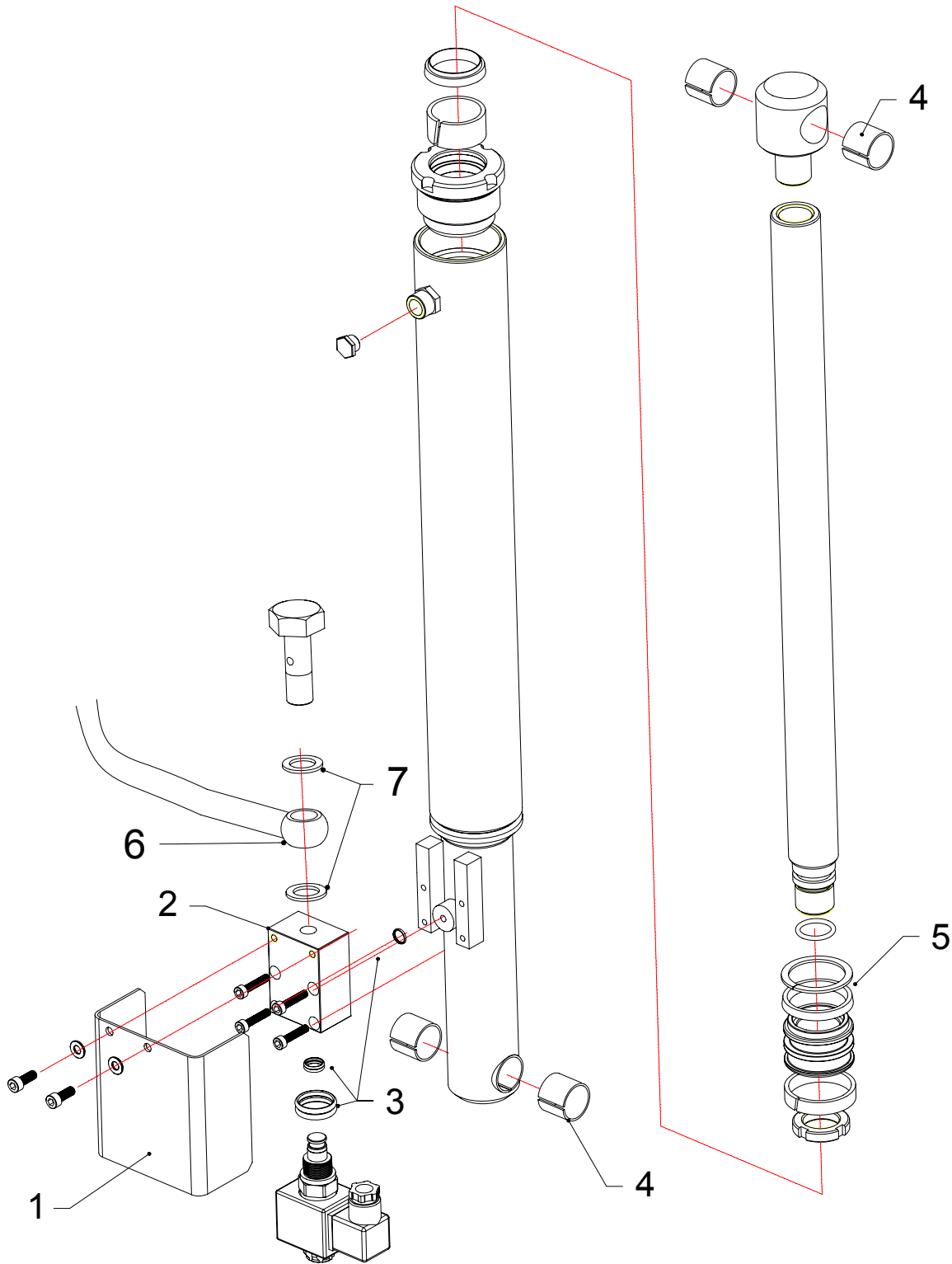

Item Ref	Part No.	Description	Qty.
1	81904026	Pressure loss valve cover	1
2	81904006	Pressure loss valve	1
3	81801003	Pressure loss valve o-rings	1
4	81070091	Bush	4
5	81801004	Seal kit	1
6	82904014	X2 hydraulic hose	1
7	81904031	Pressure loss valve seal kit	1

BoSS X3X Base Unit Assembly

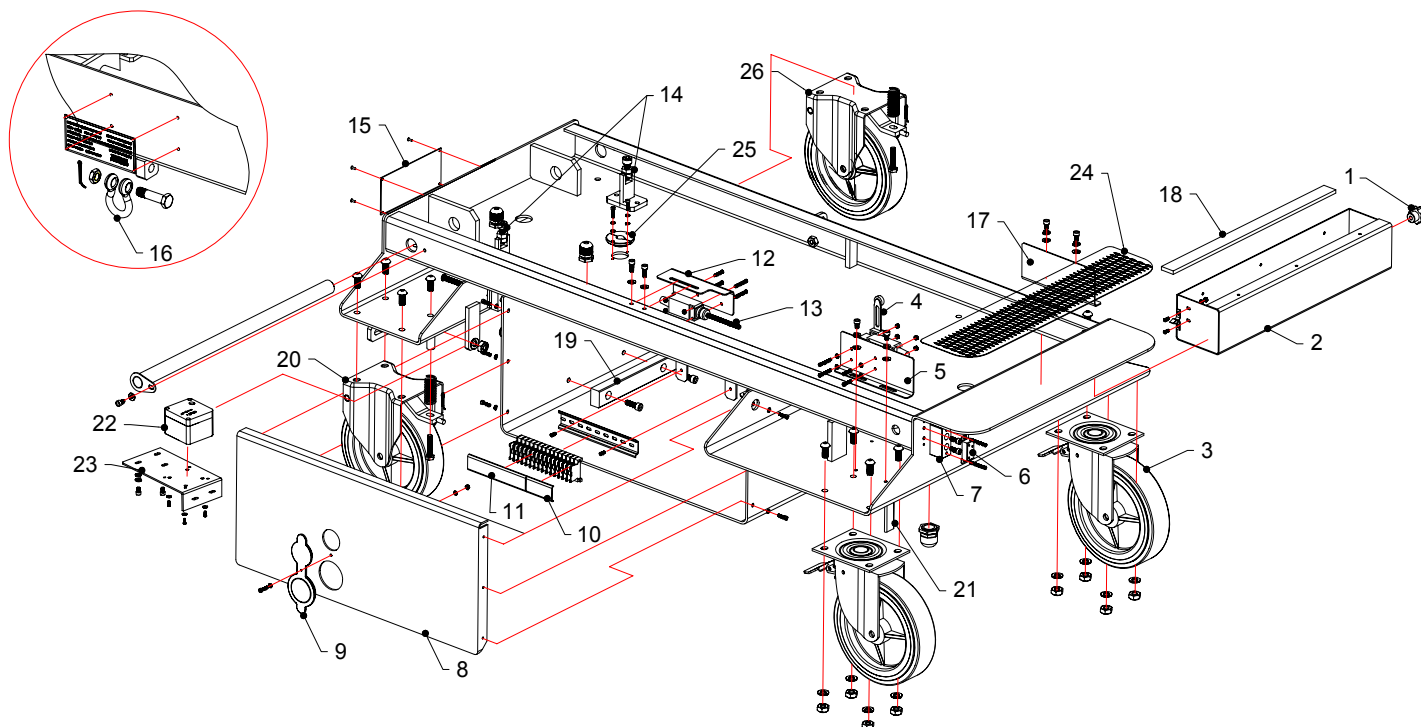

Item Ref	Part No.	Description	Qty.
1	81905027	Charging cables drawer knob	1
2	81905018	Charging cables drawer	1
3	81905030	Braked swivel castor	2
4	83905010	Descent cut-out limit switch	1
5	83905008	Descent cut-out switch protection plate	1
6	81905040	Charging cables drawer clip	1
7	81905039	Charging cables clip block	1
8	81905022	Base back plate assembly	1
9	81905038	Waterproof cover	1
10	81910035	Tilt sensor connector cover	1
11	81910034	Connector cover	1
12	81905015	Steel protector for height limit switch	1
13	81910018	Height limit switch	1
14	81801005	Fixed castor brake assembly	1
15	81905041	Machine plate – stamped with details	1
16	81905025	Winching eye	1
17	83905009	Blanking plate	1
18	81801006	Charging cables drawer rail	2
19	81905024	Drawer runner	2
20	81905031	Left fixed castor	1
21	81905028	Anti static strip	1
22	83801007	Tilt sensor	1
23	81801008	Assembly plate for tilt sensor	1
24	81905029	Slip resistant step cover	1
25	81090141	Hydraulic hose fixing	1
26	81905042	Right fixed castor	1

BoSS X3X/X3/X2 Base Unit Drawer Assembly

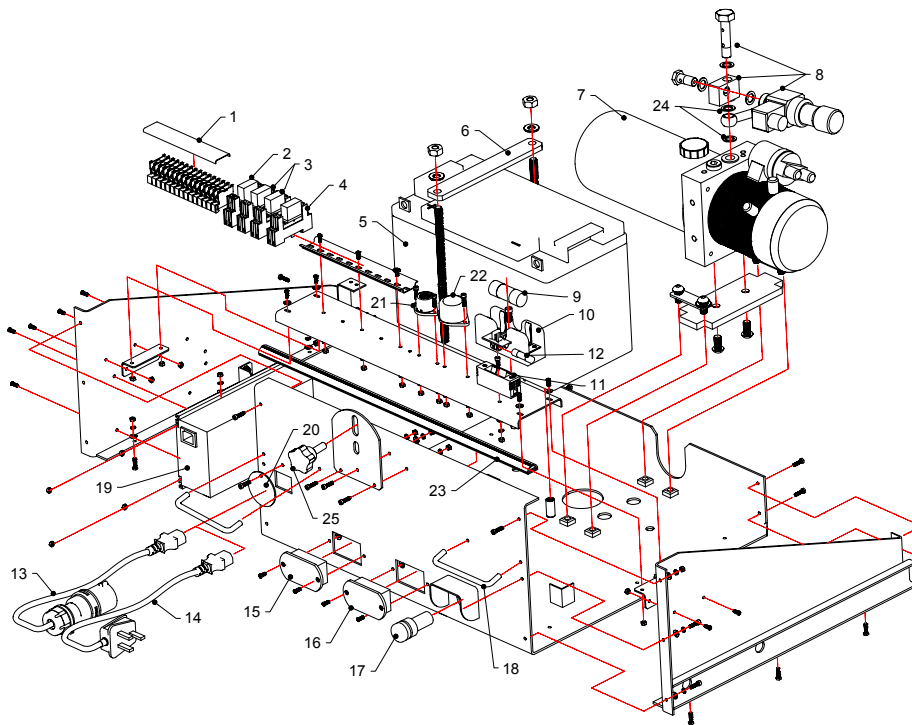

BoSS X3X/X3 Base Unit Drawer Assembly

Item Ref	Part No.	Description	Qty.
1	81910043	Transparent connector cover	1
2	81801009	Relay assembly 16A	1
3	81801010	Relay assembly 5A	2
4	81801011	Timer relay assembly	1
5	81120581	Battery 100A	1
6	81907014	Battery fixing plate	1
7	81910078	Power pack 1.2kW	1
8	81801012	Pressure sensor assembly	1
9	81801013	Fuse 100A	1
10	81801015	Fuse 100A base	1
11	81801014	Fuse 5A base	1
12	81910041	Fuse 5A	1
13	81120821	110V charging cable	1
14	81120811	Mains charging cable	1
15	81910083	Charging indicator	1
16	81910062	Battery level indicator	1
17	81120491	Emergency stop button	1
18	81909037	Handle	2
19	81910082	Charger 12A	1
20	81907017	Charging point cover	1
21	81910051	Descent alarm	1
22	81910050	Tilt alarm	1
23	81909038	Rubber seal on top of drawer	1
24	81904030	Pressure sensor seal kit	1
25	81040181	Drawer closer bolt	1

BoSS X2 Base Unit Drawer Assembly

Item Ref	Part No.	Description	Qty.
1	81910043	Transparent connector cover	1
2	81801009	Relay assembly 16A	1
3	81801010	Relay assembly 5A	2
4	81801011	Timer relay assembly	1
5	82910003	Battery 80A	1
6	81907014	Battery fixing plate	1
7	82910002	Power pack 0.8kW	1
8	81801012	Pressure sensor assembly	1
9	81801013	Fuse 100A	1
10	81801015	Fuse 100A base	1
11	81801014	Fuse 5A base	1
12	81910041	Fuse 5A	1
13	81120821	110V charging cable	1
14	81120811	Mains charging cable	1
15	81910083	Charge indicator	1
16	81910062	Battery level indicator	1
17	81120491	Emergency stop button	1
18	81909037	Handle	2
19	82910004	Charger 8A	1
20	81907017	Charging point cover	1
21	81910051	Descent alarm	1
22	81910050	Tilt alarm	1
23	81909038	Rubber seal on top of drawer	1
24	81904030	Pressure sensor seal kit	1
25	81040181	Drawer closer bolt	1

BoSS X3X/X3/X2 Power Pack Assembly

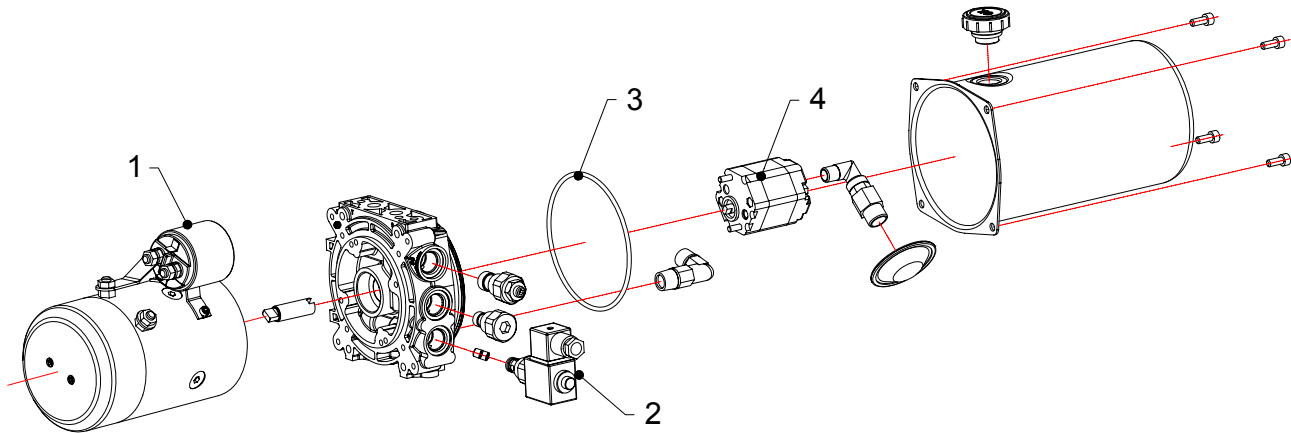

Item Ref	Part No.	Description	Qty.
1	81100021	Motor contactor	1
2	81100091	Solenoid & emergency release valve	1
3	81801018	O-ring	1
4	81801019	Pump	1

BoSS X3X/X3/X2 Confined Space Guardrail Assembly (Accessory available to purchase separately)

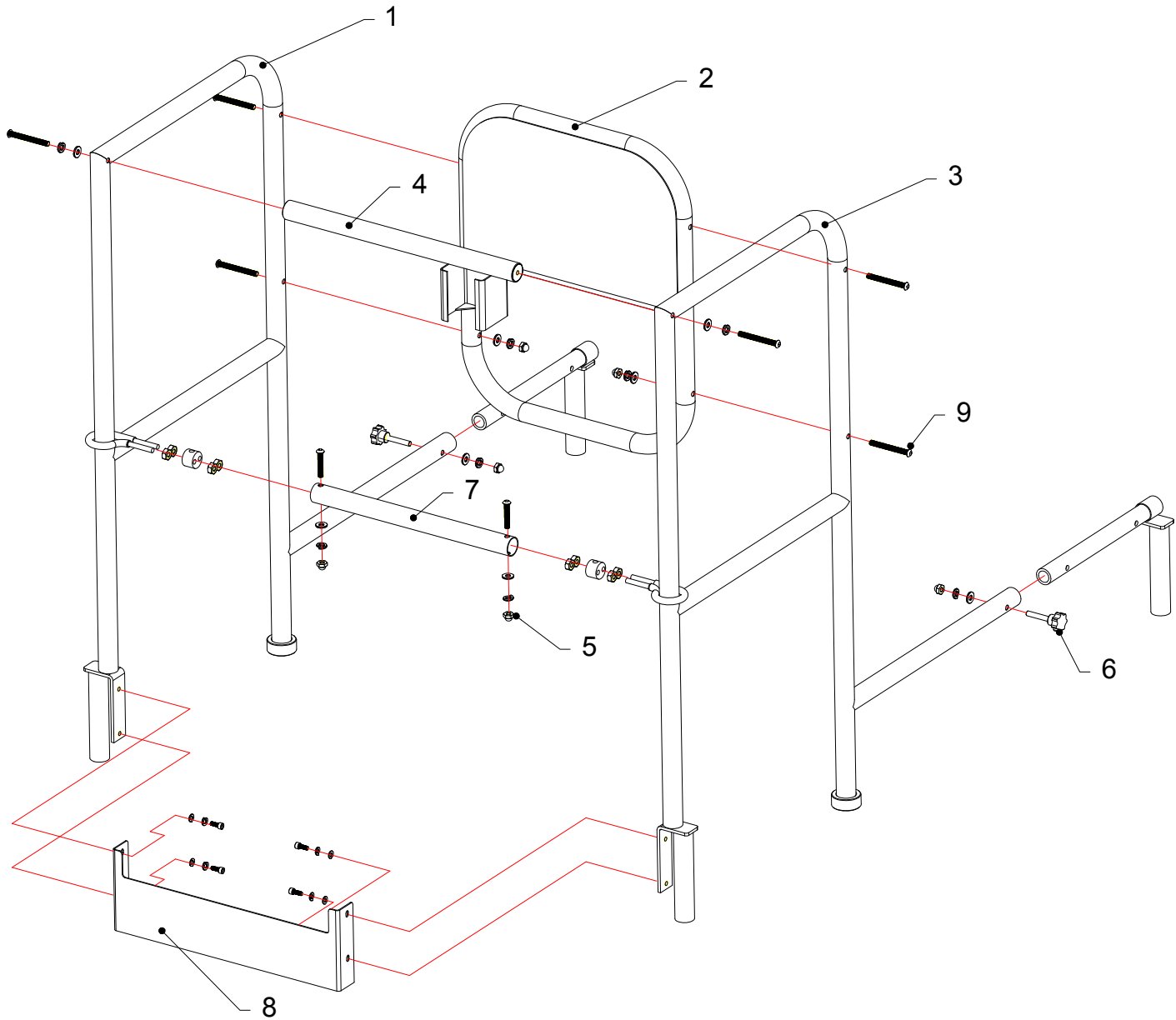

Item Ref	Part No.	Description	Qty.
1	81250241	Left guardrail assembly	1
2	81250021	Back guardrail assembly	1
3	81250251	Right guardrail assembly	1
4	81250081	Top bar	1
5	81250211	Sliding bar gate fixings	1
6	81250221	Handle screws M8	2
7	81250091	Slider bar assembly	1
8	81250071	Toeboard	1
9	81250231	Guardrail fixings	1

SECTION 7 - ELECTRICAL SCHEMATIC

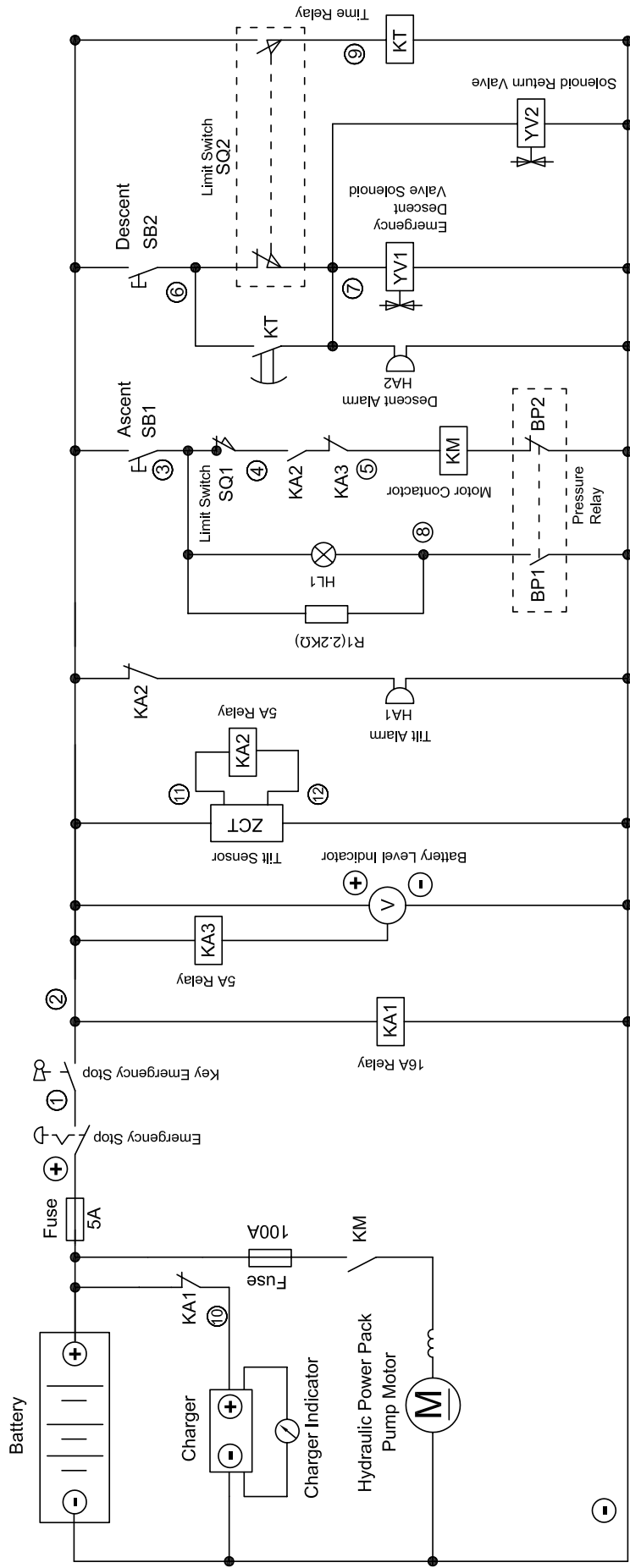

SECTION 8 - WIRING DIAGRAM

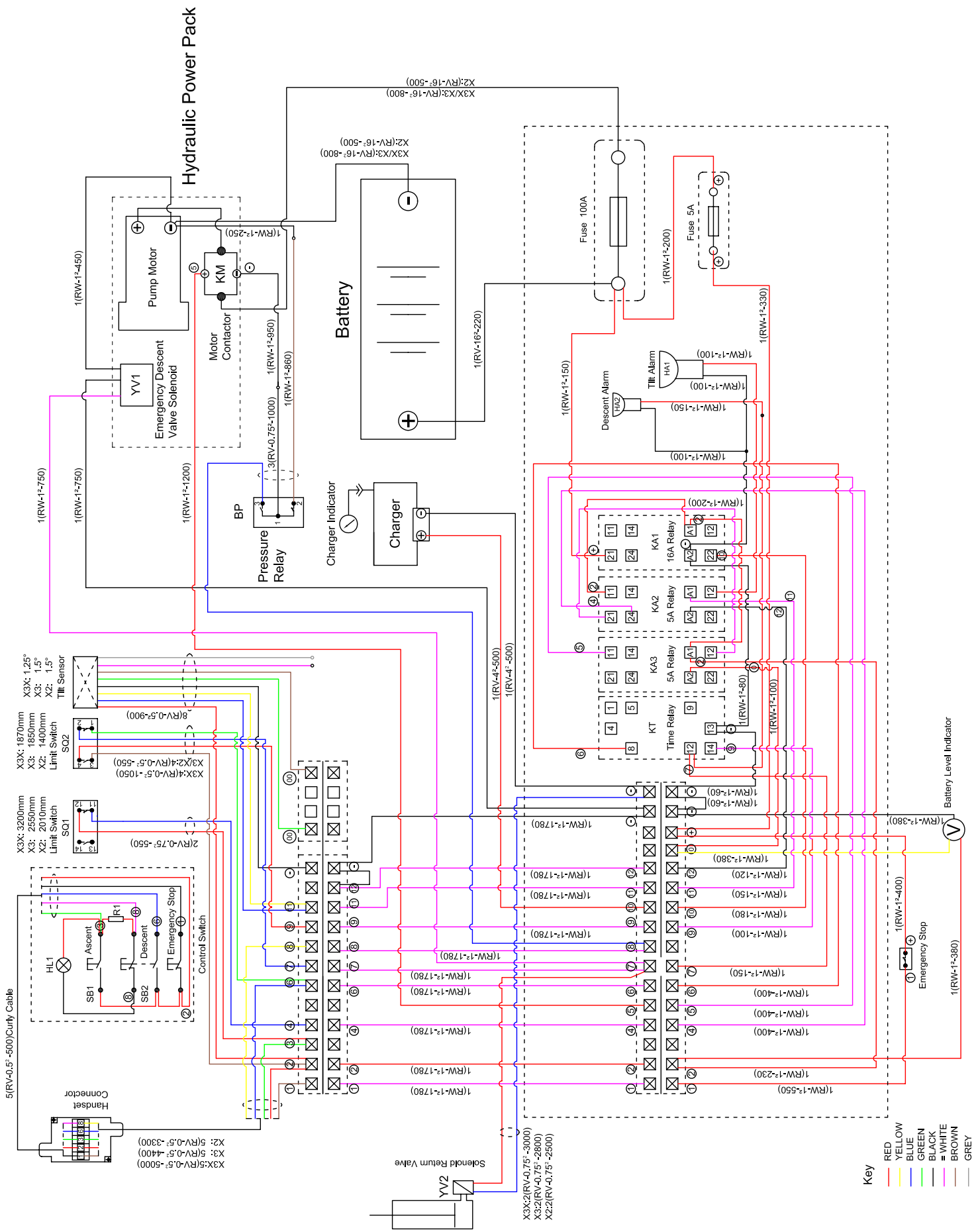

SECTION 9 - TILT SENSOR

The tilt sensor is programmed to trigger if the angle of inclination of the chassis of the BoSS X3X exceeds 1.25° or for the BoSS X3 and X2 the angle is 1.5°. This applies to the tilt sensor built into the machine and any replacement tilt sensor supplied by Youngman or our approved parts distributor.

Should a replacement tilt sensor be fitted to the BoSS X-Series machine it must be zero calibrated (0 – 0.02°) once fitted to the chassis and with the chassis level on both the lateral and longitudinal axes as determined by the use of a suitable inclinometer. Once the level is achieved the two points on the zero connector block (see figures 1 and 2 below) should be bridged with a piece of wire for three seconds (see figure 3) and the sensor will then be calibrated to 0 – 0.02°. The machine must be switched on and the platform raised and held in place by the fail-safe props during this calibration process.

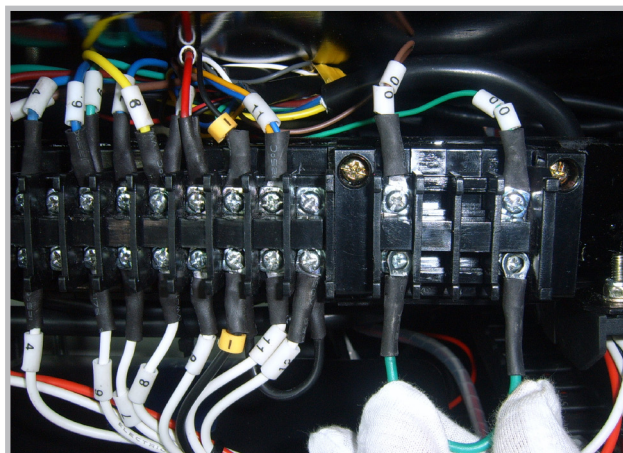

Figure 3

WARNING

Failure to correctly calibrate the tilt sensor will result in a failure of the tilt sensor to operate normally and could result in the serious injury or death of any subsequent operator of the BoSS X-Series machine.



Figure 1

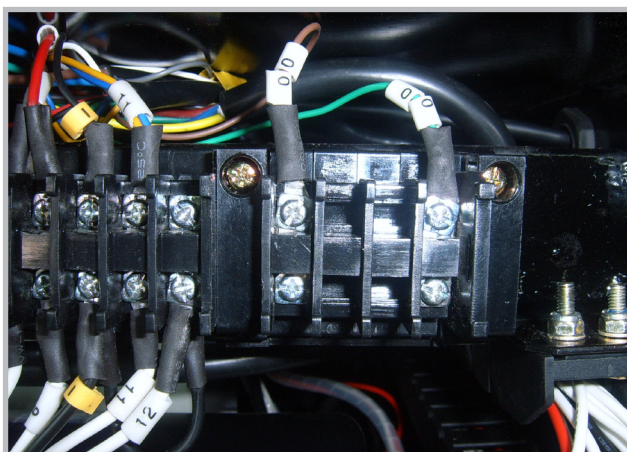
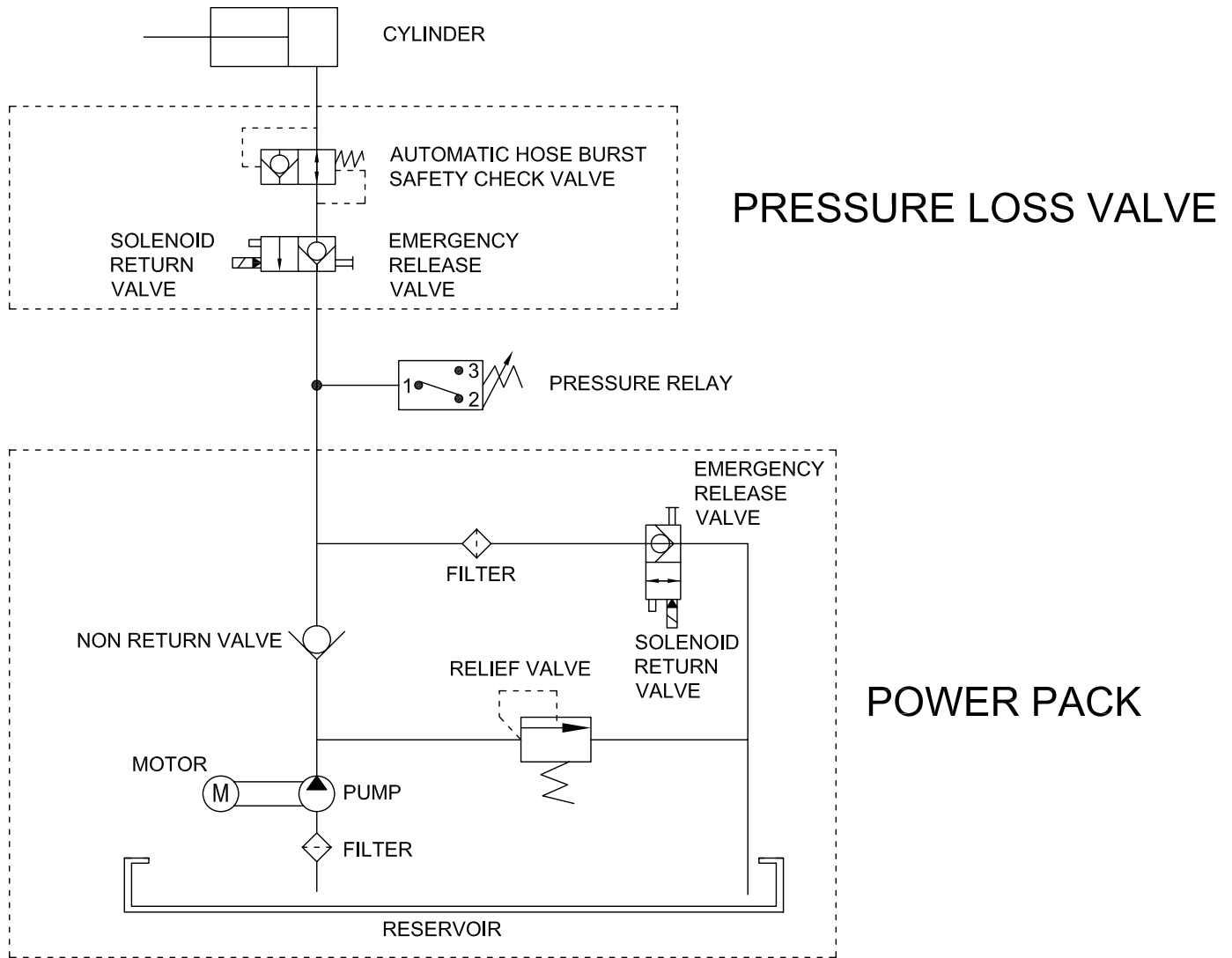

Figure 2

SECTION 10 - HYDRAULIC SCHEMATIC



SECTION 11 - MACHINE LABELLING

See below for the correct location of the BoSS X-Series labels and machine plate

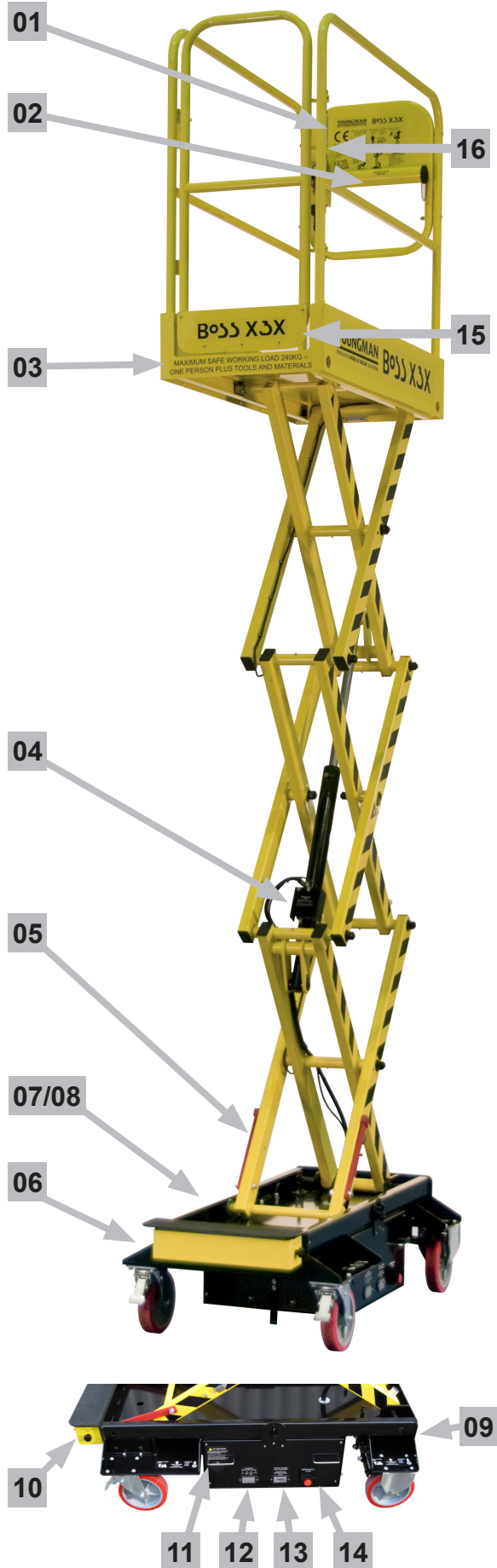

01 **YOUNGMAN BOSS X3X**
 INNOVATIVE WORK AT HEIGHT SOLUTIONS

CE

- BOSS X3X IS DESIGNED FOR INDOOR USE ONLY. IT MUST NOT BE USED OUTDOORS.
- MAXIMUM WIND SPEED: 12 METRES PER SECOND.
- PAYING PARTICULAR ATTENTION TO THE SAFETY RULES MUST BE OBSERVED AT ALL TIMES. THE USER MANUAL MUST BE READ AND UNDERSTOOD BEFORE USE. LOCATED IN THE TOOL BOX BEFORE OPERATING THIS MACHINE.
- ENSURE BOTH SWIVEL CASTOR WHEELS ARE LOCKED BEFORE ELEVATING THE PLATFORM.
- NEVER WORK ON LIVE TOOLS & MATERIALS (ELECTRIC).
- DO NOT ATTEMPT TO OVERREACH.
- DO NOT ATTEMPT TO MOVE THE PLATFORM WHEN ELEVATED.
- ALWAYS USE THE EMERGENCY STOP AT 1.8 METRES ABOVE THE PLATFORM AND A SAFE CONTINGENCY PRESS THE DOWN BUTTON.

02 **INSTRUCTIONS FOR USE**

04 **PRESSURE LOSS VALVE**

IN THE EVENT OF A LOSS OF POWER OR HYDRAULIC PRESSURE TURN THE VALVE ANTICLOCKWISE UNTIL IT WILL NOT TURN ANY FURTHER.

PRIOR TO THE RESTORATION OF POWER AND / OR HYDRAULIC PRESSURE CLOSE THIS VALVE BY TURNING CLOCKWISE.

03 **MAXIMUM SAFE WORKING LOAD 240KG – ONE PERSON PLUS TOOLS AND MATERIALS**

05 ENSURE BOTH MAINTENANCE PROPS ARE IN POSITION BEFORE UNDERTAKING MAINTENANCE ON THE RAISED PLATFORM.

06 **FORK LIFTING POINT**

↑ PASS TRANSIT STRAPS THROUGH HERE ↓

MAXIMUM WHEEL LOAD 450KG

On all four forklift and transit strap points

07 **TO LOWER THE PLATFORM WITHOUT POWER IN AN EMERGENCY**

- TURN THE VALVE ON THE PRESSURE LOSS VALVE ON THE HYDRAULIC RAM ANTICLOCKWISE UNTIL IT WILL NOT TURN ANY FURTHER.
- TURN THE VALVE ADJACENT TO THIS LABEL ANTICLOCKWISE UNTIL THE PLATFORM BEGINS TO DESCEND TO STOP THE PLATFORM AT ANY TIME, TURN THE VALVE CLOCKWISE.

PRIOR TO THE RESTORATION OF POWER TURN BOTH VALVES CLOCKWISE UNTIL FULLY TIGHT AND THEN USE THE HANDSET CONTROLLER IN ACCORDANCE WITH THE INSTRUCTIONS FOR USE.

DO NOT USE A PRESSURE WASHER ON THIS SIDE OF THE BASE UNIT UNLESS BOTH RUBBER PLUGS ARE IN POSITION.

08

09

MANUFACTURER: YOUNGMAN GROUP LIMITED	COUNTRY OF MANUFACTURE: PRC	
MODEL: BoSS X	SERIAL NUMBER: YMG	YEAR OF MANUFACTURE:
MASS (UNLOADED):	KG	RATED LOAD: 240KG=1 PERSON+160KG TOOLS & MATERIALS
MAXIMUM MANUAL FORCE:	200N	MAXIMUM WIND SPEED: 0 M/S
MAXIMUM CHASSIS INCLINATION:		YOUNGMAN INNOVATIVE WORK AT HEIGHT SOLUTIONS The Causeway, Maldon, Essex, CM9 4LJ United Kingdom
BATTERY CHARGER:	AUTOMATIC 110/240V	

Located on end of the chassis

10 **CHARGING CABLES & GUARDRAIL TOOLS**

11 **ATTENTION**

PRESS THE EMERGENCY STOP BUTTON ON THE HANDSET AND REMOVE THE KEY PRIOR TO CHARGING.

POWER SUPPLY: 110 OR 240 VOLTS. SELECT THE APPROPRIATE CABLE FROM THE CHARGING CABLES AND GUARDRAIL TOOL BOX MOUNTED ON THE GUARDRAIL AND PLUG IN BELOW.

12 **CHARGER INDICATOR LIGHTS**

- AC POWER SUPPLY
- CHARGE BATTERY CAPACITY
- CHARGE BATTERY CAPACITY
- CHARGING INDICATOR 20% OF BATTERY CAPACITY

13 **BATTERY CHARGE LEVEL INDICATOR:**

LED DISPLAYS BATTERY CHARGE LEVEL

14 **EMERGENCY STOP**

15 **HARNES LANYARD POINT**

↓

16 **OVERLOAD**

SECTION 11 - MACHINE LABELLING CONTINUED

Item Ref	Part No.	Description	Qty.
1	83911031	X3X branding decal set	1
2	83911032	X3X safety decal set	1
1	81911031	X3 branding decal set	1
2	81911032	X3 safety decal set	1
1	82911031	X2 branding decal set	1
2	82911032	X2 safety decal set	1

SECTION 12 - STORAGE

The BoSS X-Series machine should be stored inside in a secure, clean and dry environment, the emergency stop on the handset depressed and the key removed. It should not be stored outside.

When the BoSS X-Series machine is parked the swivel castor brakes must be applied and if the machine has to be parked on a gradient the castors must be chocked. The BoSS X-Series machine must not be stored where the air temperature exceeds 50°C or falls below -20°C.

SECTION 13 - TROUBLESHOOTING

Problem	Cause	Repair
Platform does not raise (motor not running)	Faulty wiring	Check the wiring referring to the wiring diagram
	Battery is disconnected	Reconnect the battery
	Battery charge is insufficient	Charge the battery
	Tilt sensor has been triggered	Reduce operating angle
Platform does not raise (motor running)	Platform is overloaded	Reduce platform load
	Faulty adjustment of relief valve	Adjust relief valve
	Faulty hydraulic pump	Replace pump
	Insufficient hydraulic oil	Add hydraulic oil
Platform creeps (uncontrolled lowering)	Oil leakage in power pack	Replace lowering valve
	Oil leakage from hydraulic circuit	Check hydraulic circuit and repair
Oil leaking from cylinder	Faulty sealing	Replace sealing
Oil leaking from piping or joint	Insufficient tightening or seal invalid	Tighten joint or replace seal
Oil leaking from air breather	Excessive quantity of oil	Reduce oil quantity

SECTION 14 - DISPOSAL

At the end of its life the BoSS X-Series machine should be taken to a licensed centre for recycling.

SECTION 15 – MODIFICATIONS TO LATER BOSS X-SERIES MACHINES (REFER TO SERIAL NUMBERS AT START OF THIS SECTION)

In accordance with the Youngman Group policy of continuous product development we have introduced the following four changes to machines.

These changes are effective on machines with the following or later serial numbers:

- BoSS X3X – YMG 32001
- BoSS X3 – YMG 12001
- BoSS X2 – YMG 22001

The following three changes apply to all three machines:

- Tool box moved from under the step up to the platform and fitted to the guardrail as shown below.



- Width of gate reduced to prevent trapping of fingers as shown below.



- Pressure loss release moved from the ram to under the step up to the platform as shown below.



This changes the **EMERGENCY LOWERING** procedure for machines fitted with this new mechanism:

1. Turn the emergency valve on the base unit anticlockwise until it will not turn any further as shown in *figure 1*.

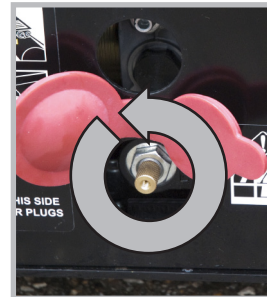

Figure 1

2. Pull the pressure loss valve release handle, shown in *figure 2* below, which is mounted under the step up to the platform, until the platform lowers. It at any time you need to stop the descent simply release the handle.

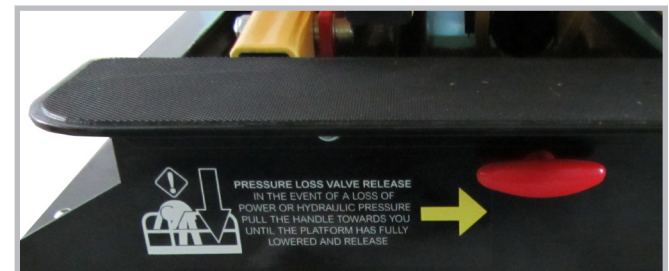

Figure 2

WARNING

Always ensure someone other than the operator is trained to perform this rescue.

In addition, in order to shorten the length of the BoSS X3X for transport, the step has been redesigned to be detachable as shown below.



The stowed length of the BoSS X3X is reduced from 1.41 to 1.3 metres when the step is removed.

The following exploded drawings and tables have been revised to show these machine changes and the new spare parts required. If any spare part is not listed here please refer to Section 6.

BoSS X3X/X3/X2 Guardrail Assembly – showing new tool box and narrow gate

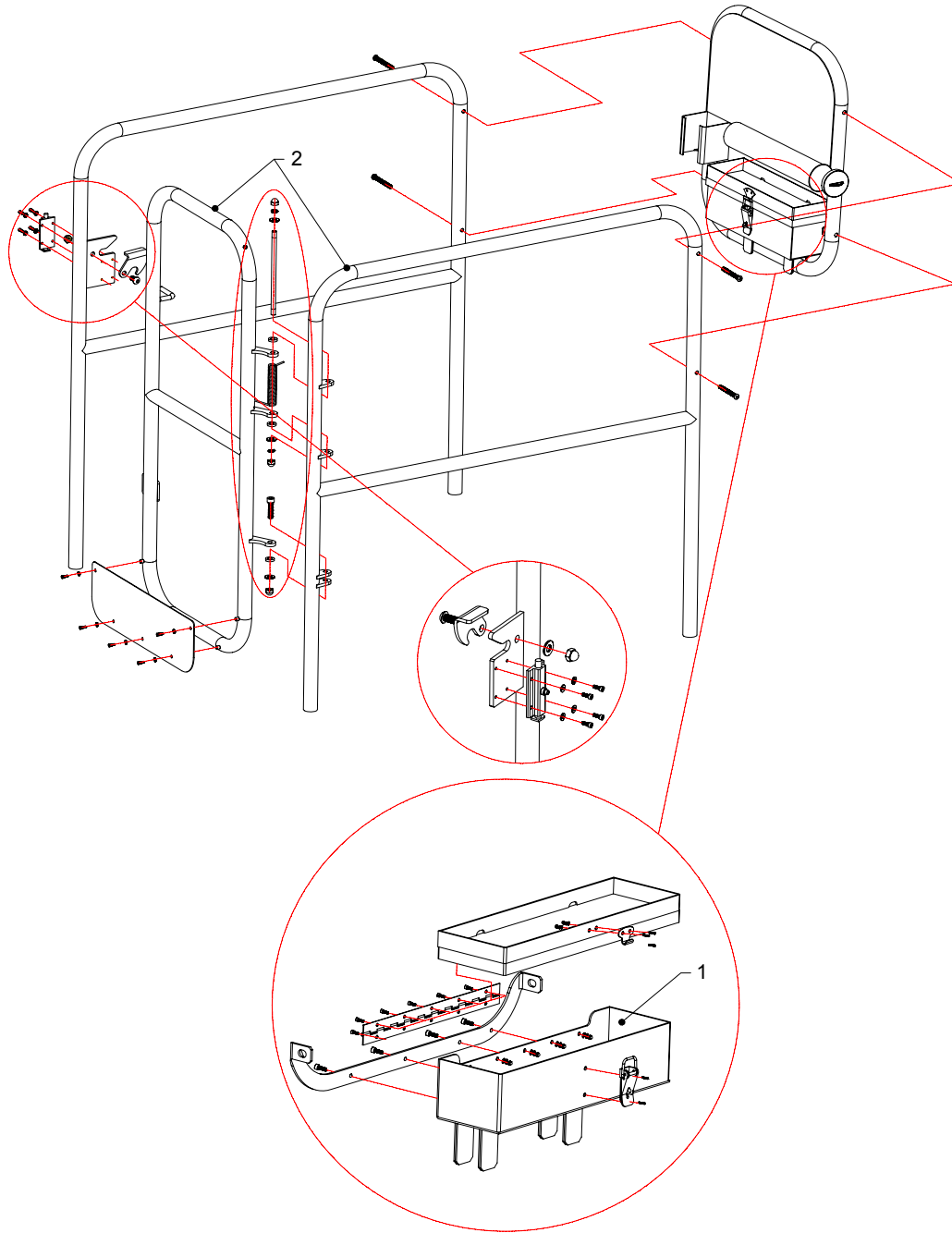

X3X Guardrail Assembly

Item Ref	Part No.	Description	Qty.
1	81200501	X-Series tool box	1
2	83801020	Right guardrail & narrow gate assembly	1

X3 Guardrail Assembly

Item Ref	Part No.	Description	Qty.
1	81200501	X-Series tool box	1
2	81801020	Right guardrail & narrow gate assembly	1

X2 Guardrail Assembly

Item Ref	Part No.	Description	Qty.
1	81200501	X-Series tool box	1
2	82801020	Right guardrail & narrow gate assembly	1

BoSS X3X/X3 Hydraulic Cylinder Assembly – showing new pressure loss valve arrangement

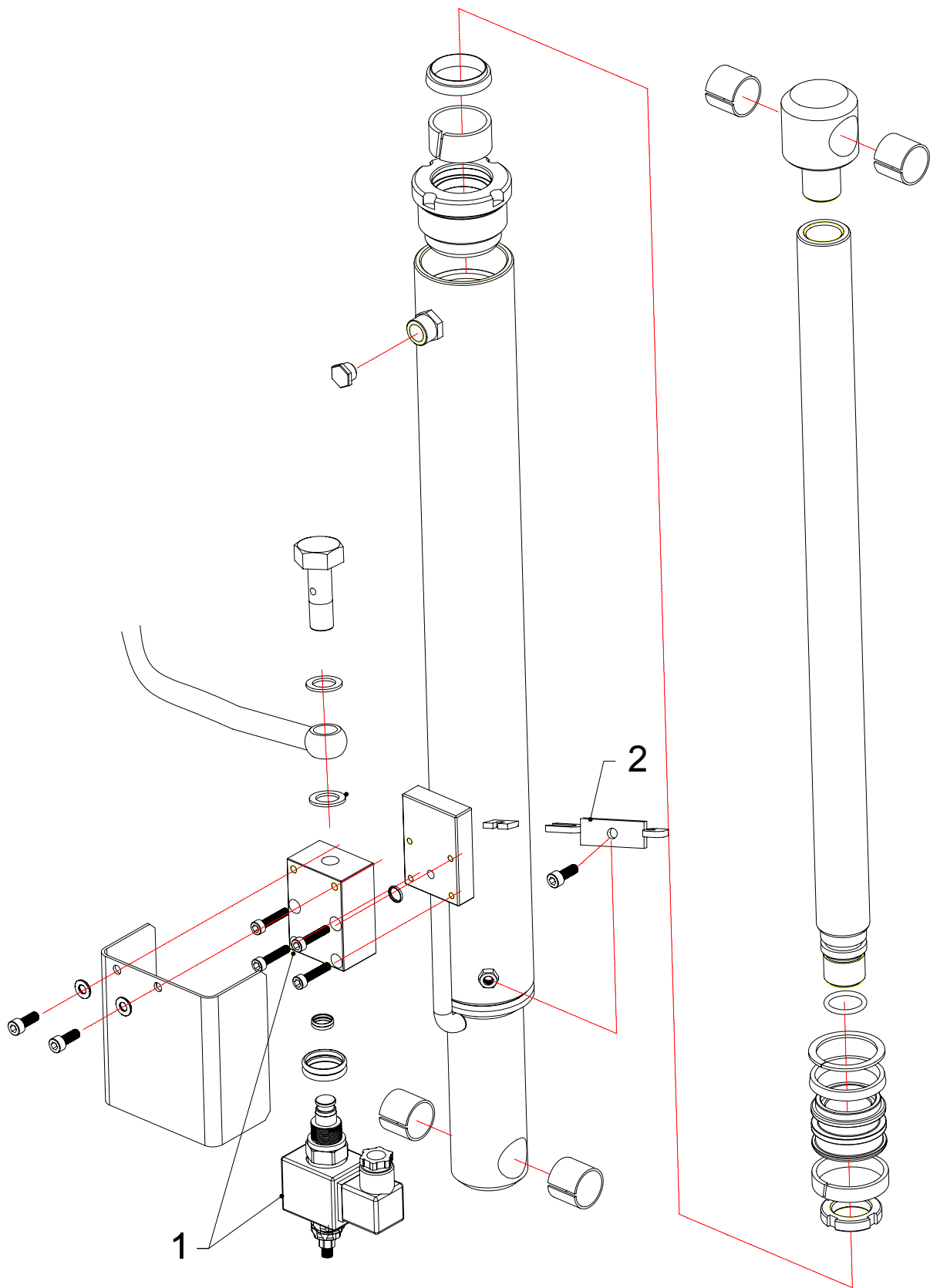

Item Ref	Part No.	Description	Qty.
1	81911021	Pressure loss valve assembly – handle type	1
2	84040019	Pressure loss valve release linkage	1

BoSS X2 Hydraulic Cylinder Assembly – showing new pressure loss valve and cover arrangement

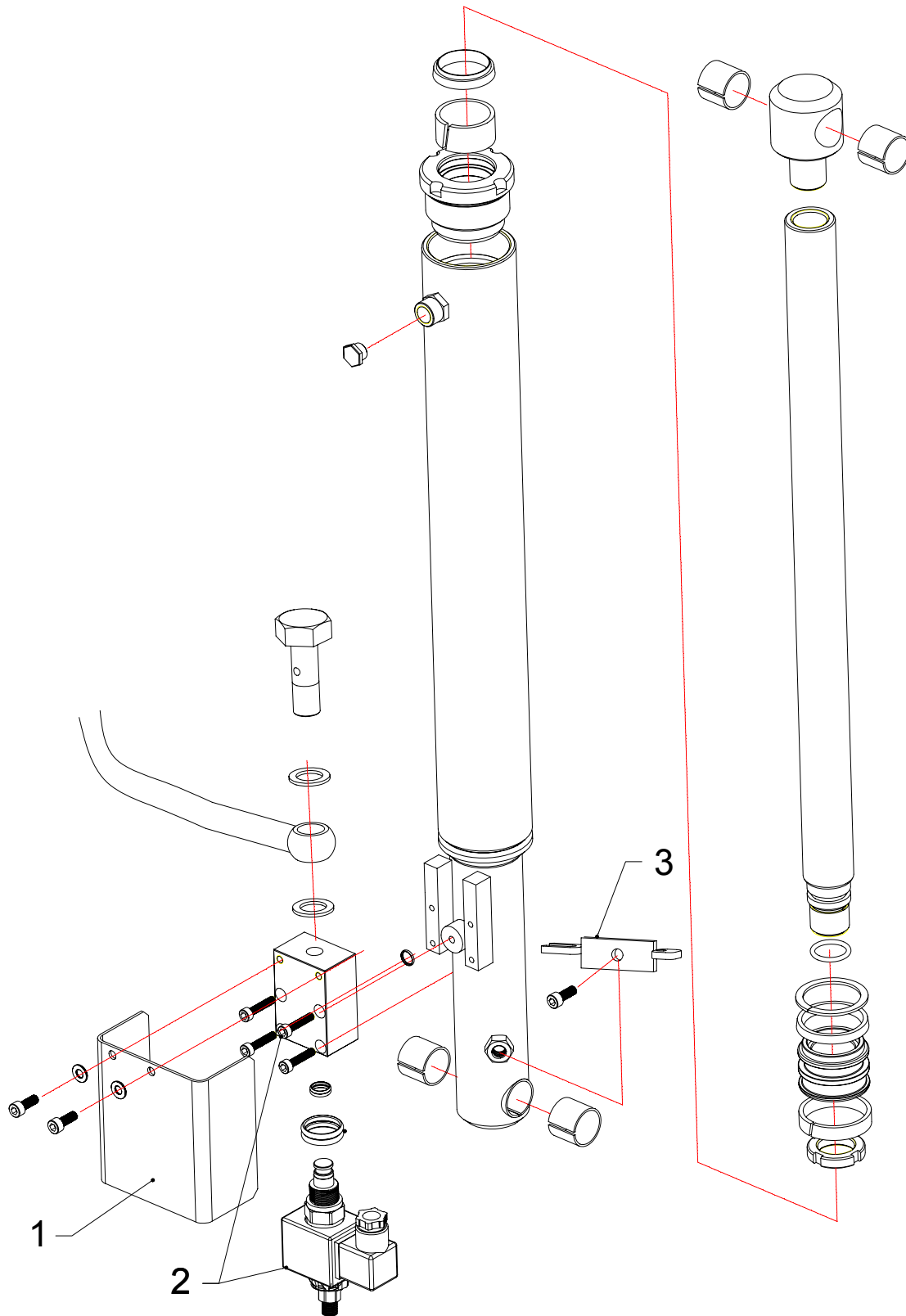

Item Ref	Part No.	Description	Qty.
1	82904026	Pressure loss valve cover – handle type	1
2	81911021	Pressure loss valve assembly – handle type	1
3	82040019	Pressure loss valve release linkage	1

BoSS X3X Base Unit Assembly – showing emergency pressure loss valve release handle and detachable step

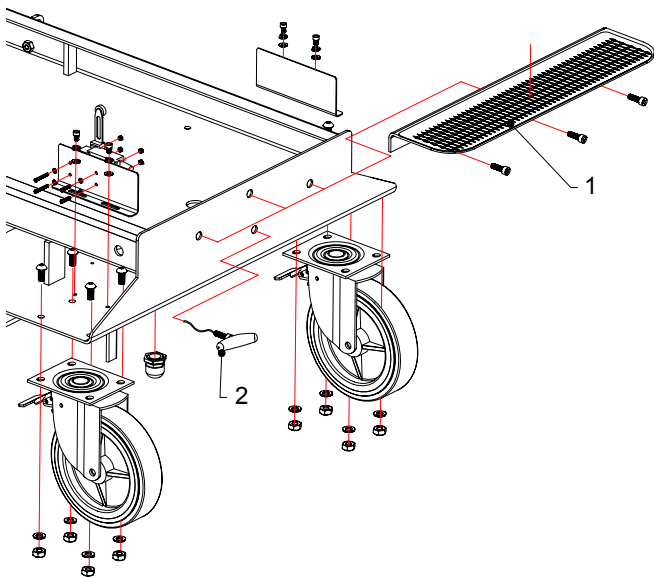

Item Ref	Part No.	Description	Qty.
1	83911019	Detachable step	1
2	83911020	X3X emergency pressure loss valve release handle	1

BoSS X3/X2 Base Unit Assembly – showing emergency pressure loss valve release handle

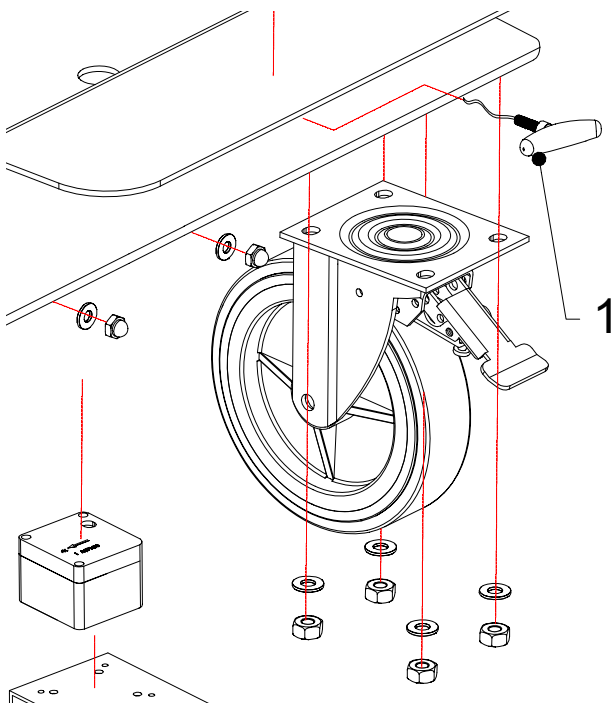

BoSS X3

Item Ref	Part No.	Description	Qty.
1	81911020	X3 emergency pressure loss valve release handle	1

BoSS X2

Item Ref	Part No.	Description	Qty.
1	82911020	X2 emergency pressure loss valve release handle	1

As a result of these machine changes four new labels have been added to the machines – see positioning in pictures below.



Tool box

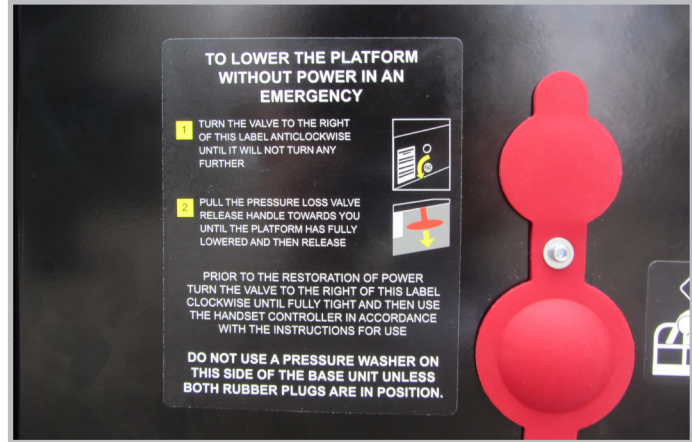

Emergency descent procedure



Charging point



Emergency pressure loss valve release handle

Part No.	Description	Qty.
BoSS X3X Safety Decal Set (revised)		
83911034	BoSS X3X safety decal set (revised)	1
BoSS X3 Safety Decal Set (revised)		
81911034	BoSS X3 safety decal set (revised)	1
BoSS X2 Safety Decal Set (revised)		
82911034	BoSS X2 safety decal set (revised)	1

APPENDIX

Report of a Thorough Examination

Reference: "Lifting Operations and Lifting Equipment Regulations 1998" Regulation 10 Schedule 1

1. Company: _____
Address: _____
2. Site address (if different from above): _____
3. **Equipment**
Manufacturer: _____ Serial number: _____
Model: _____ Year of manufacture: _____
4. Date of last thorough examination: _____
5. Safe working load: _____
6. (a) Is this the first thorough examination since assembly? **YES / NO**
(b) Is it safe to operate? **YES / NO**
7. a(i) Is this a thorough examination of lifting equipment for lifting persons within an interval of 6 months under regulation 9(3)(a)(i) ? **YES / NO**
(iii) Is it in accordance with an examination scheme? **YES / NO**
(iv) Is it due to exceptional circumstances e.g. major repair? **YES / NO**
(b) Is it safe to operate? **YES / NO**
8. (a) Description of defect or defective part: _____
(b) Details of repair required: _____
(c) Details of a dangerous or potentially dangerous defect:
(i) Time by which it could become a danger _____
(ii) Particulars of any repair to remedy it _____
(d) Date next thorough examination is due: _____
(e) Details of any test:
Safe Working Load: _____
Overload: _____
(f) Other observations and recommendations: _____
9. Engineers name: _____
Engineers CAP number: _____
Engineers signature: _____
Employed by: _____
Address: _____
10. Clients appointed representative: _____
Clients appointed representative signature: _____
Address: _____

YOUNGMAN

INNOVATIVE WORK AT HEIGHT SOLUTIONS



EN 280 IP24

For further information about these or any of our other products and services please contact:

Youngman Group Ltd
The Causeway, Maldon,
Essex, CM9 4LJ,
United Kingdom

t +44 (0)1621 745900
f +44 (0)1621 859845
e sales@youngmangroup.com

youngmangroup.com